



APPLICATION OF QUASI-Z-SOURCE INVERTER IN PHOTOVOLTAIC GRID-CONNECTED SYSTEMS

Dr. Turki Kahawish Hassan

Assist Prof., Electrical Engineering Department, College of Engineering, Al-Mustansiriyah University, Baghdad, Iraq.

Abstract: In this paper, a single phase quasi-Z-source inverter with maximum power point tracking (MPPT) is proposed for photovoltaic (PV) system. A boost DC-DC converter is used to implement the MPPT algorithm for tracking the maximum power from a PV panel. Perturb & Observe (P&O) method is used as a maximum power point tracker due to its simplicity. The suggested quasi-Z-source inverter employs the quasi-Z-source network and only two active switches to achieve the same output as the traditional voltage-fed full bridge inverter does. The proposed quasi-Z-source inverter has small size, lower cost and high efficiency since no any transformer is used (the input dc source and the output ac voltages share the same ground). Nonlinear sinusoidal pulse width modulation (SPWM) is used to produce sinusoidal inverter output voltage. Power simulation (PSIM) program is used for simulation and the obtained results show the validity of the proposed DC-AC conversion system.

Keywords: quasi-Z-source inverter, photovoltaic (PV), MPPT, boost converter

استخدام مبدل شبيه مصدر الممانعة في الانظمة الفوتوفولطائية المربوطة للشبكة

الخلاصة: في هذا البحث تم اقتراح مبدل نوع شبيه مصدر الممانعة للنظام الفوتوفولطائي وباستخدام طريقة الحصول على القدرة العظمى. استعمل المحول للتيار المستمر نوع (boost) لغرض بناء متابع نقطة قيمة القدرة القصوى (MPPT) وباستخدام (P&O method) كونها سهلة الاستخدام. المبدل نوع (quasi-Z-source) يتكون من شبكة نوع (quasi-Z-source) ومفتاحين فعالين (two active switches) مقارنة بالفتطرة التامة للمبدلات التقليدية. من خصائص المبدل المقترح الحجم الصغير والكلفة القليلة وكذلك الكفاءة العالية وذلك لعدم استخدام اي محولة لقد استخدام تحميل عرض النبضة اللاخطي للحصول على فولتية اخراج جيبيية من المبدل. البرنامج نوع (PSIM) تم استخدامه في المحاكاة ونتائج المحاكاة اثبتت صلاحية نظام التحويل المقترح من التيار المستمر الى التيار المتناوب.

1. Introduction

Renewable energy sources, like wind turbine, solar photovoltaic (PV) and fuel cell are becoming more famous in the recent years. This is because of increasing the demand for clean energy. The solar photovoltaic sources produce DC voltages at the output therefore inverters are required to place in between the source of energy and the grid or AC loads.

Isolated and non-isolated inverters are widely used for connecting renewable energy sources with the utility grid. The problems of using isolated inverters are high system

*Corresponding Author : thassan2013@yahoo.com

cost, larger system size and reduced efficiency. In contrast, use of non-isolated inverters reduce both cost and size along with improved system efficiency but these inverters require some safety issues to be considered, like minimization of connection effect between the input DC source and the grid as well as DC current injection to the utility grid and loads [1]. If the same ground is not shared by both the PV panel and the grid, a variable common voltage is developed which causes large common-mode leakage current to flow through the parasitic capacitor between PV panel and the ground, therefore the quality of the grid current is reduced and the system losses is increased. Also the electromagnetic interference is induced [2-5].

To solve above problems, doubly grounded topologies are used [2,3,6]. Hence, in this paper, preference has been given to the doubly grounded transformerless inverters topology. Enhancement of the performance of the transformerless inverters is possible by designing the passive components of the inverters.

The authors [7-10] show that choosing of coupled inductor is better than separate inductor from the point of view of reduce the input current ripple, output voltage ripple and minimize the inverter size. In this paper, a single phase transformerless doubly grounded quasi-Z-source inverter for PV system with MPPT is proposed. The proposed system utilizes a boost DC-DC converter for tracking the maximum power of the PV panel and a single phase quasi-Z-source inverter for DC-AC conversion.

The single phase quasi-Z-source inverter requires only two active switches to produce sinusoidal output voltage which is the benefit of this topology over traditional single phase Z-source full bridge inverters. The complete system is able to extract maximum power of a PV panel and produces AC voltage at the output of the inverter by using only three active switches (one active switch for boost DC-DC converter and two active switches for quasi-Z-source inverter).

2. Operation Principle of the Proposed Single Phase Quasi-Z-Source Inverter with MPPT

Figure 1 shows the proposed single phase quasi-Z-source inverter with MPPT. In the following sections, boost DC-DC converter with MPPT and single quasi-Z-source inverter are explained.

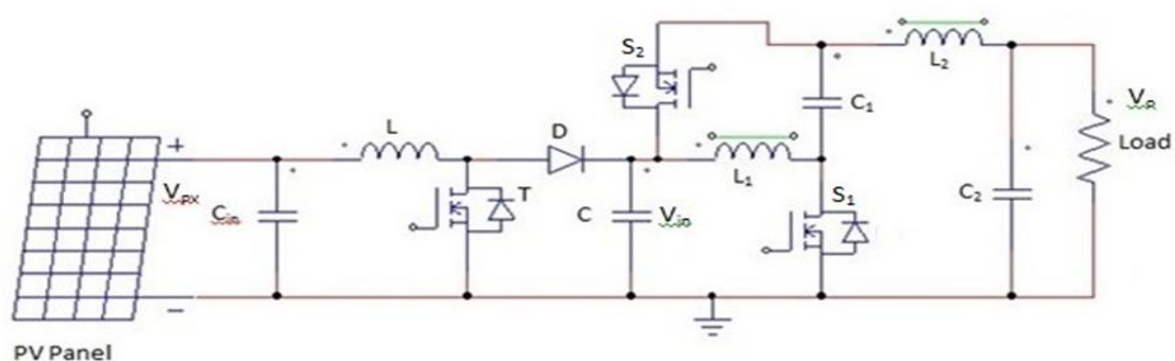

Figure.1 Proposed single phase quasi-Z-source inverter with MPPT

2.1. PV System with Boost DC-DC Converter

A boost DC-DC converter has been used for tracking the maximum power point (MPP) of the PV panel. As shown in Fig.1, the boost converter consists of inductor (L), transistor (T), diode (D) and capacitor (C). The electrolytic capacitor (C_{in}) is used for decoupling and smoothing the PV panel voltage. The relationships between the voltage and current of the converter at the input and output sides are shown in Equations (1) and (2). Equation (3) shows that the duty cycle can be regulated, and thus, the resistance (load line) of the converter can be varied until the load line cuts through the I-V curve at MPP [11,12].

$$V_{boost} = \frac{V_{pv}}{1 - K} \quad (1)$$

$$I_{out} = (1 - K)I_{in} \quad (2)$$

Equation (1) is then divided by Equation (2) to obtain:

$$R_{in} = (1 - K)^2 R_o \quad (3)$$

Where V_{pv} is the input voltage of the boost converter or the voltage of PV panel ;K is the duty cycle; V_{boost} is the output dc voltage of boost converter; I_{in} is the input current of the boost converter; R_{in} is the input resistance of the converter; R_o is the output resistance of the converter.

Perturb and observe (P&O) method which is also called “Hill-Climbing” is widely used technique for MPPT because of its simplicity and effectiveness [12,13]. The perturbation in the operating voltage of the DC link voltage between the PV panel and boost converter is repeatedly done.

In this method, PV power ($p(k)$) is calculated and compared with the previous calculated PV power ($p(k-1)$). If the power increases, the same perturbation is applied in the same direction to get the same power, otherwise perturbation is made in opposite direction.

By this process, the operating point of the system gradually moves toward the MPP and oscillates around it. Based on these facts the algorithm is implemented. The process is repeated until the MPP is reached [14,15]. P&O MPPT method is used in this paper. The flowchart of P&O algorithm is shown in Figure (2).

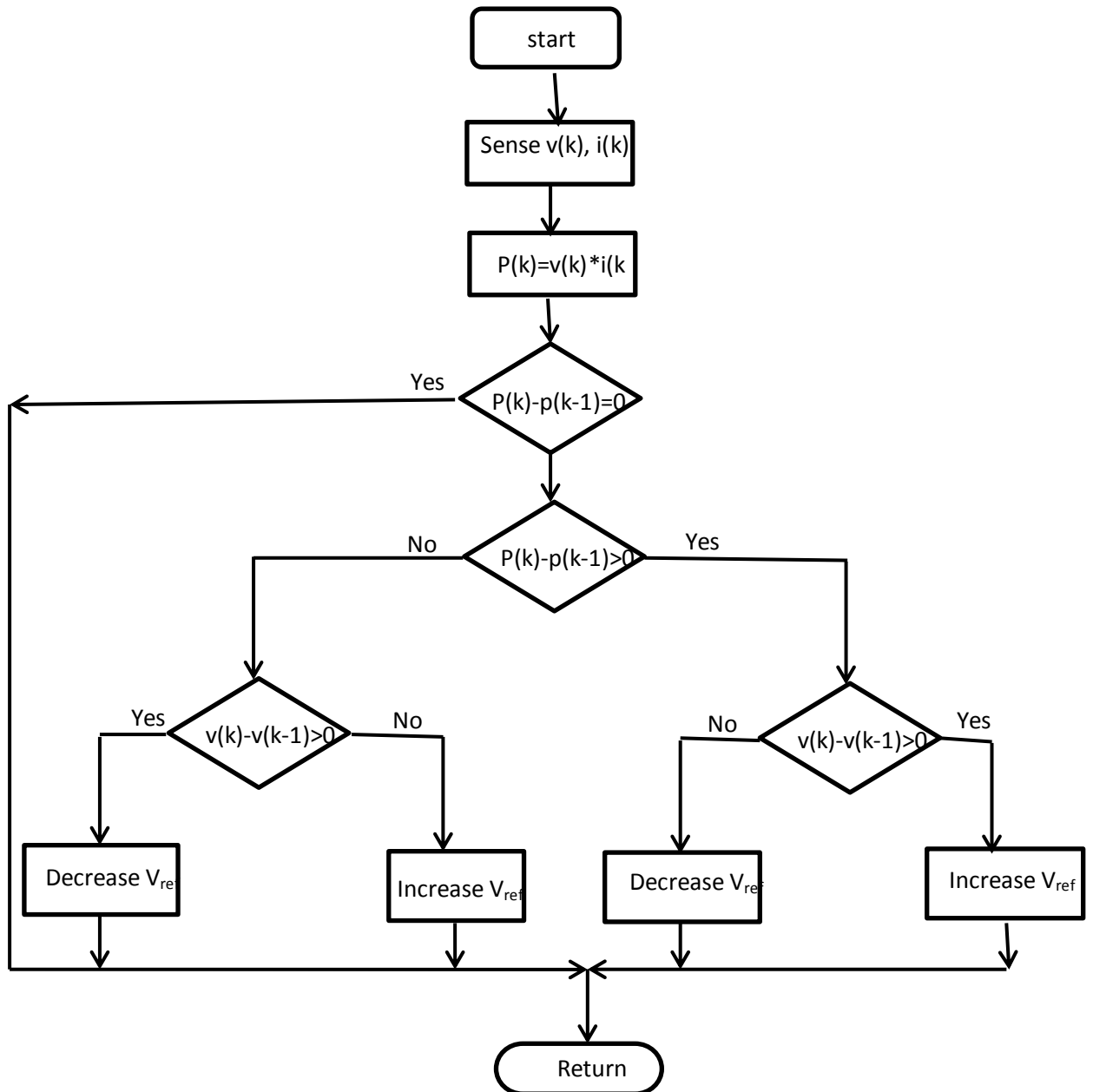
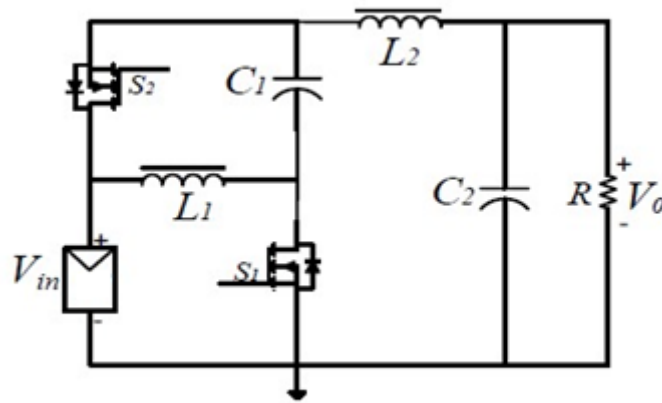

Figure 2. P&O algorithm for MPPT

2.2 Basic Principle of Transformerless Quasi-Z-Source Inverter

Figure (3a) shows the transformerless single phase quasi-Z-source inverter with ground sharing [1,17] nature, While Fig.3b shows the continuous voltage curve of the converter. Positive and negative voltage can be obtained at the output of inverter when the duty ratio (D) varies between 0 and 1. As shown in Figure 3b, the inverter can generate voltages between $-V_{in}$ to $+V_{in}$ at the output of inverter when the duty cycle changes remains between 0 and $2/3$. The output is positive when the duty cycle of switch S_1 varies from 0 to $1/2$, whereas the output is negative when the duty cycle of switch S_1 varies from $1/2$ to $2/3$. For duty cycle of $1/2$, the inverter produces zero voltage at the output [18].



(a)

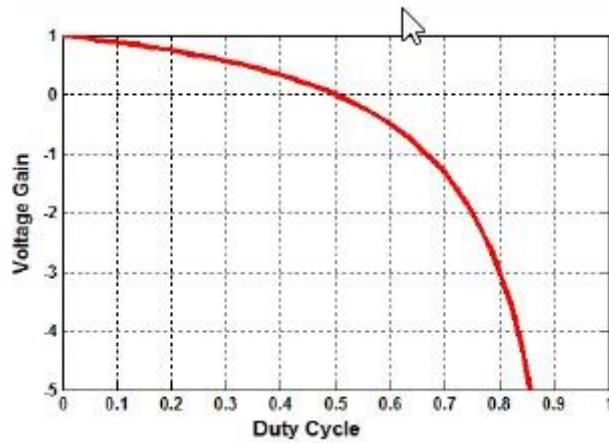

(b)

Figure 3. Single-phase quasi-Z-source inverter and voltage gain curve, (a) single-phase quasi-Z-source inverter ,(b) voltage gain curve.[1].

The direction of current references of the inductors and the voltage references of capacitors are shown in Figs. 4a and b for the following steady-state equations. The steady-state equations are derived based on voltage-second balance and capacitor charge balance principle [17]. The steady-state equations are as follows:

$$\frac{V_o}{V_{in}} = \frac{1-2D}{1-D} \tag{4}$$

$$V_{C1} = \frac{D}{1-D} V_{in} \tag{5}$$

$$I_{L2} = -I_o \tag{6}$$

$$I_{L1} = -\frac{D}{1-D} I_o \tag{7}$$

If the inverter output voltage is sinusoidal as shown in equation (8) then the modulation index can be expressed as in (9). Equation (10) has been derived from (4), (8) and (9)

$$V_o = V \sin \omega t \tag{8}$$

$$M = \frac{V}{V_{in}} \tag{9}$$

$$D = \frac{1 - M \sin \omega t}{2 - M \sin \omega t} \tag{10}$$

The duty cycle of switch S_2 (D') can be expressed as:

$$D' = 1 - D \tag{11}$$

$$D' = \frac{1}{2 - M \sin \omega t} \tag{12}$$

Where V_{in} is the dc output voltage of boost converter (V_{boost}), V_o is the output of quasi-Z-source inverter, V is the amplitude of output voltage V_o . As shown in (12), there is a non-linear relation between voltage gain or modulation index (M) and duty cycle (D'), therefore a non-linear sinusoidal pulse width modulation (SPWM) is used to generate sinusoidal output voltage. Fig. 4c shows a non-linear SPWM method. In this method a derived reference signal in Equation (12) is used to control the duty cycle of switch S_2 . To turn on switch S_2 , it is necessary the reference value should be greater than carrier value. Equation (10) shows the reference signal of S_1 , which is complementary of S_2 and the range of duty cycle is between 0 and 1.

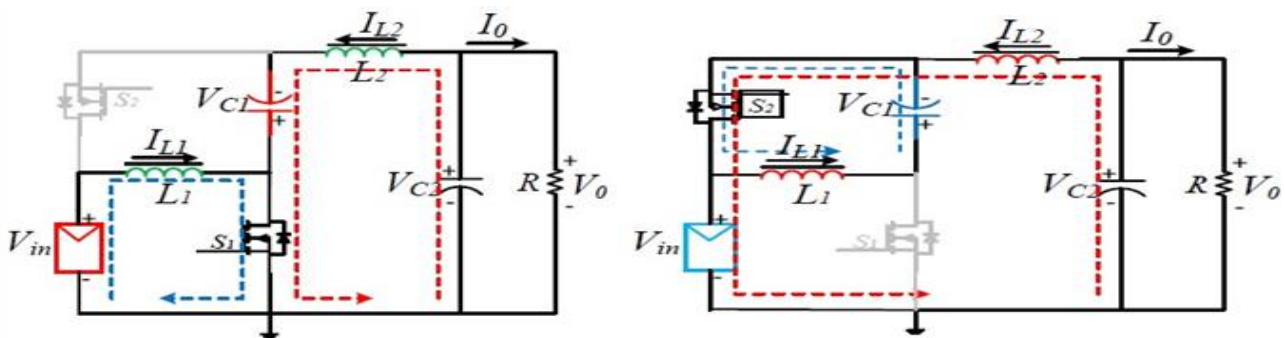

(b)

(a)

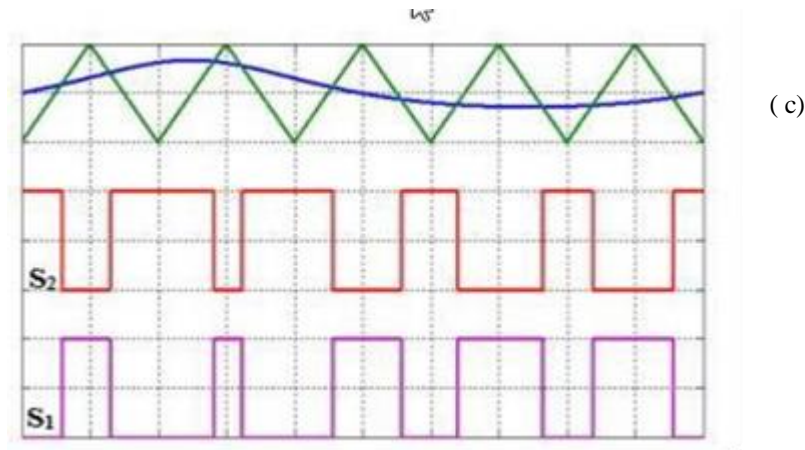

Fig. 4 Quasi-Z-source inverter: (a) Modes of operation of quasi-Z-source inverter at state I. (b) Modes of operation of quasi-Z-source inverter at state II. (c) Modulation of quasi-Z-source inverter.[12]

2.3 Analysis and Design of the Quasi-Z-Source Inverter Circuit

Configuration of quasi-Z-source inverter shown in Fig.3a has been used to analyses various parameters and design consideration of the circuit components. The output current expression in (13) is in phase with output voltage. Voltage across the switch during the OFF state and the current through the switch during ON state can be presented in (14) and (15) respectively.

$$I_o = I \sin \omega t \quad (13)$$

$$V_s = V_{in} + V_c = \frac{1}{1-D} V_{in} = (2 - M \sin \omega t) V_{in} \quad (14)$$

$$I_s = I_{L1} + I_{L2} = -\frac{1}{1-D} I_o = -(2 \sin \omega t - M (\sin \omega t)^2) I \quad (15)$$

Where I is the amplitude of inverter output current, V_s is the switch voltage and I_s is the switch current.

According to (14), (15), the peak voltage across the device (the switch) occurs when $D=2/3$, $M=1$ and $\omega t=2\pi/3$ which is $3V_{in}$, the peak current through the device (the switch) also occurs when $D=2/3$, $M=1$ $\omega t=2\pi/3$ which is $3I$ respectively. The voltage and current stresses of this type of z-source inverter are high but the switching device number is reduced compared with the traditional full-bridge Z-source inverter.

Voltage across capacitor C_1 and current through inductor L_1 can be stated by (16) and (17) which are derived from (5),(7), (10) and (13). Voltage ripple of capacitor C_1 and the current ripple of the inductor can be dictated by (18) and (19) considering $L_1=L_2$. The values of capacitance C_1 and the inductance L_1 can be determined using (18) and (19) respectively [18].

$$V_{C1} = \frac{D}{1-D} V_{in} = (1 - M \sin \omega t) V_{in} \quad (16)$$

$$I_{L1} = -\frac{D}{1-D} I_o = -(\sin \omega t - M(\sin \omega t)^2) I \quad (17)$$

$$\Delta V_{C1} = \frac{(1-D)T_s I_{L1}}{C_1} = \frac{(-\sin \omega t + M(\sin \omega t)^2)T_s I}{(2 - M \sin \omega t)C_1} \quad (18)$$

$$\Delta I_{L1} = \Delta I_{L2} = \frac{V_{in} T_s D}{L_1} = \frac{V_{in} T_s (1 - M \sin \omega t)}{L_1 (2 - M \sin \omega t)} \quad (19)$$

Where V_{C1} is the voltage of capacitor C_1 , I_{L1} is the current of inductor L_1 , T_s is the switching period, ΔV_{C1} is the voltage ripple of capacitor C_1 and ΔI_{L1} is the ripple current of L_1 .

3. Simulation Model and Results

For the purpose of simulation validity, a photovoltaic (PV) panel with specifications shown in table-1 is used. Fig.5 shows the complete system that is modeled using power simulation (PSIM) software. The maximum power point (MPP) voltage of PV panel is 30V. The boost DC-DC converter with $L=1\text{mH}$ and $C=2000\mu\text{F}$ and switching frequency of 50kHz is used to raise the DC voltage and to implement the perturb and observe (P&O) MPPT algorithm. The DC output voltage of boost converter is applied to the transformerless quasi-Z-source inverter and the AC output voltage of the inverter is connected to the grid of 110V, 50Hz. The values of capacitor C_1 and C_2 of quasi-Z-source inverter are $4.7\mu\text{F}$ considering the ripple of capacitor voltage is limited to 2.22% of peak voltage across the capacitors. The important components for quasi-Z-source inverter are inductors which are used to protect the boost converter from high overload and limit the input current ripple. Two inductors (L_1 and L_2) used in quasi-Z-source inverter can be placed in a single core to reduce the size, improve the response to load change and decrease the DC leakage current injected to the grid. The values of both inductors L_1 and L_2 are 1.2mH considering current ripple limited to 1/3 of the peak current of the inductor.

To obtain sinusoidal output voltage, non-linear pulsewidth modulation is proposed as shown in Fig.5. The switching frequency of the inverter is chosen as 50kHz. Synchronous operation between the grid and inverter output voltage is shown in Fig.6

Table-1 PV Specifications

Number of cells	Series resistance	Shunt resistance	Short circuit current	Maximum power
72	0.008Ω	1000Ω	8.0 A	240W

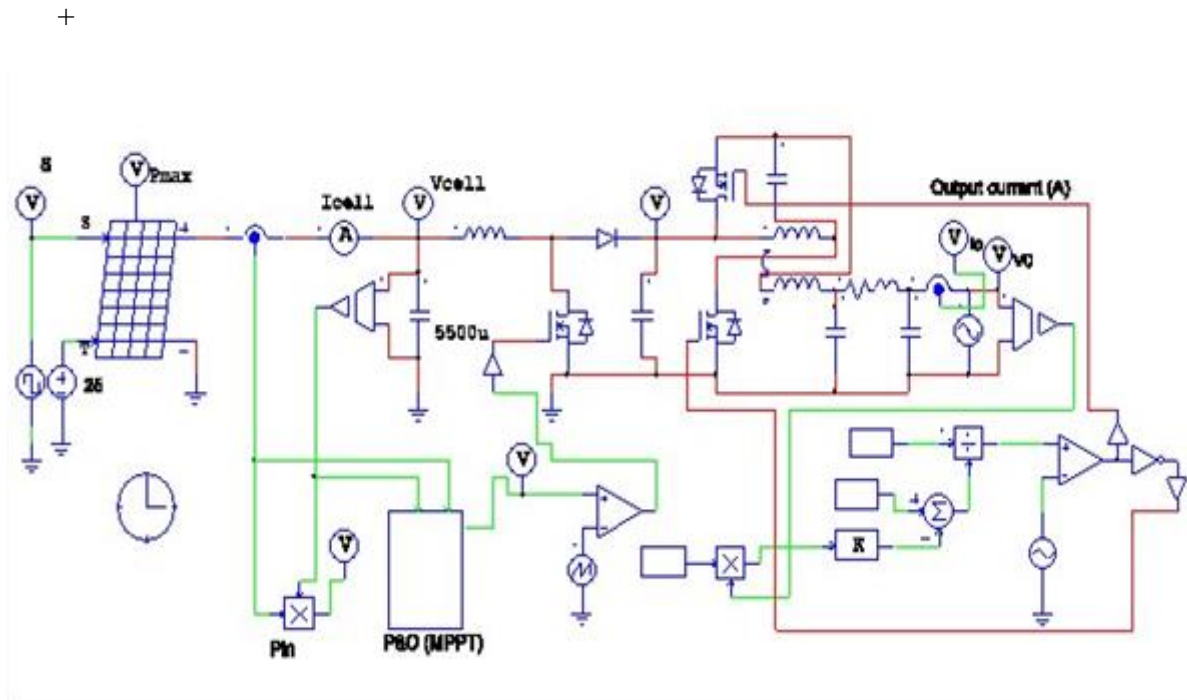

Figure 5. Simulation model for complete system using PSIM

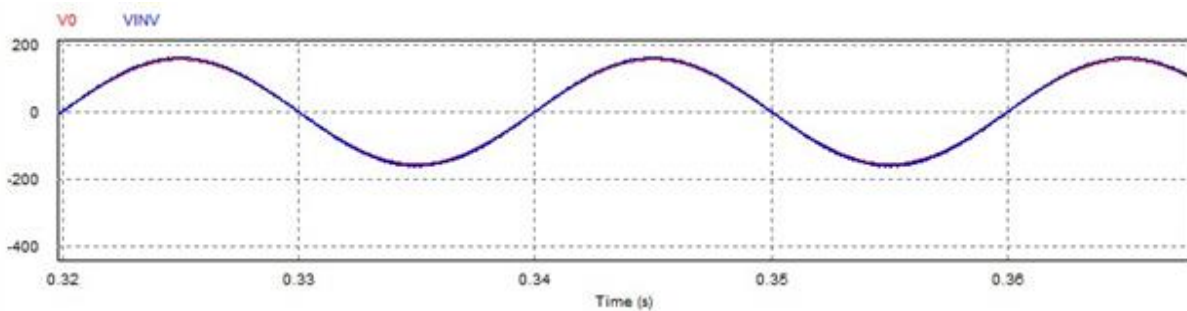

Figure 6. Grid voltage(V0) and inverter output voltage (VINV): vertical scale (200V/Div.)

Fig.7 shows the PV panel voltage (V_{cell}) and PV current (I_{cell}) at maximum power point with sun light intensity ($S=1000W/m^2$) and Fig.8 shows the dc output voltage of boost converter. The steady state value of output voltage of boost converter (V_{boost}) is 178V with ripple of 1.1% . Fig.9 shows the output current of quasi-Z-source inverter

injected into the grid and grid voltage. The RMS value of output current is 2.1A ,the power factor(Pf) is 0.92 and THD of output current is 2.69%.

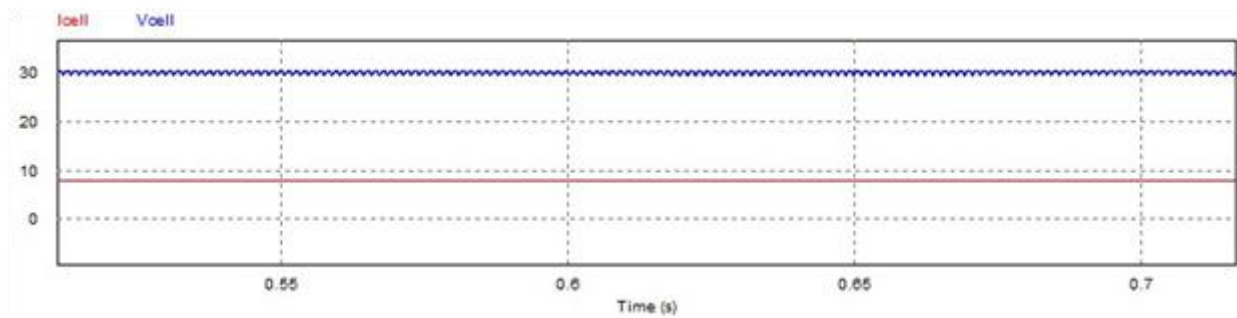

Figure7. PV panel voltage (V_{cell}) and PV panel current (I_{cell}) against time: scale for voltage (10V/Div) ,scale for current (10A/Div).

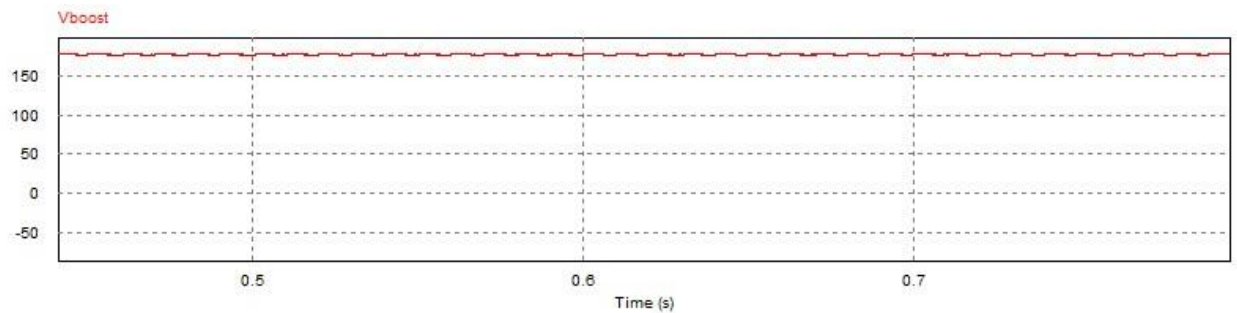

Figure 8. Output voltage of boost converter (V_{boost}) against time: scale (50V/Div.)

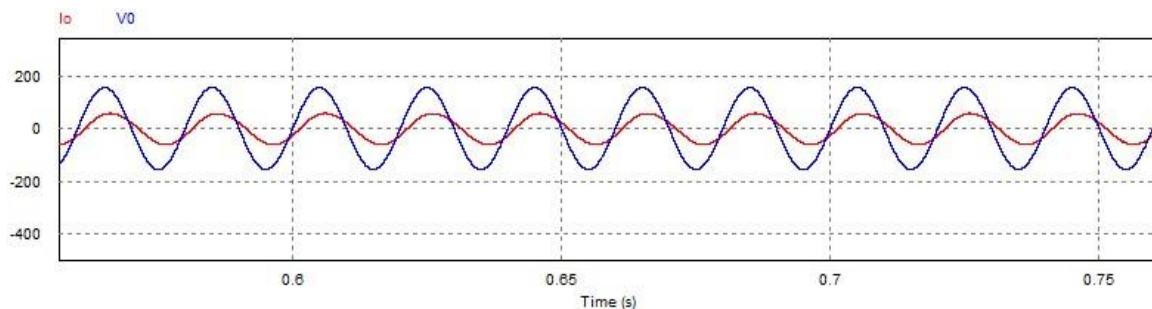
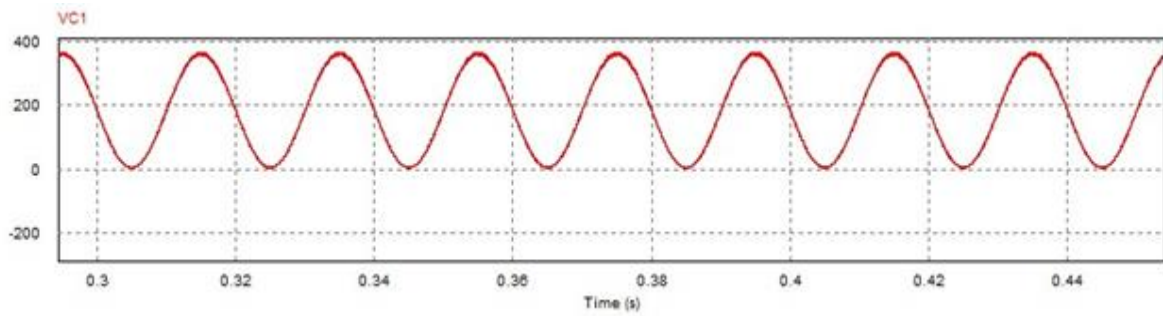
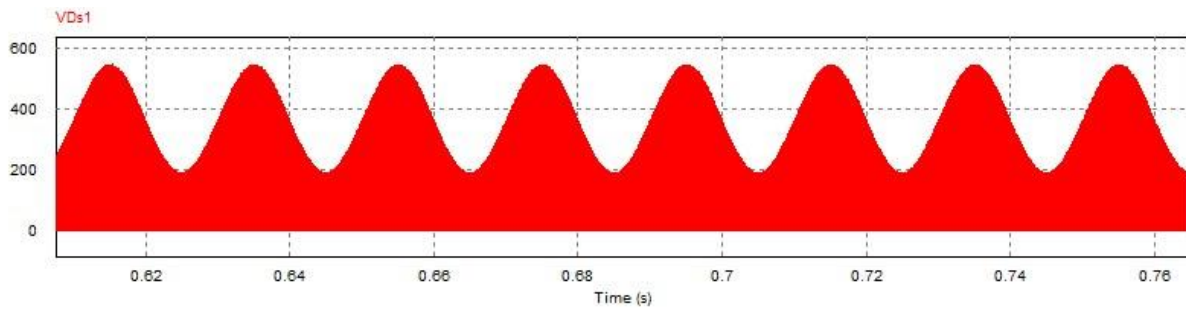
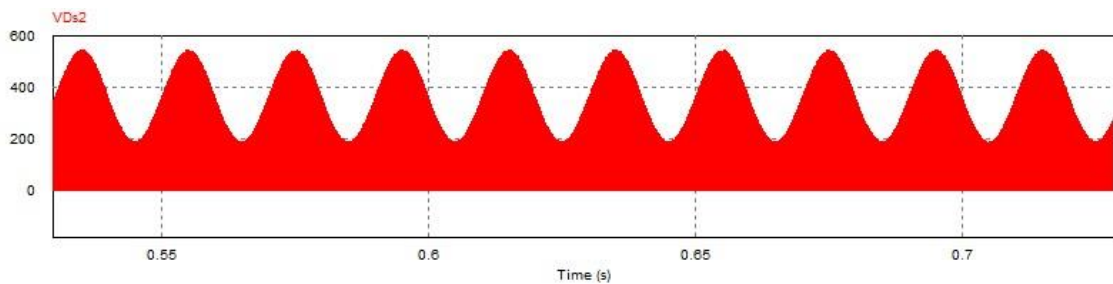

Figure 9. output current (I_o) and grid voltage(V_o) waveforms: scale for voltage (200V/Div), scale of output current (10A/Div).

The modulation index(M) is chosen as 0.968. Fig.10 shows the voltage across C_1 (V_{C1}) and Figs. 11 and 12 show the voltage across transistors V_{DS1} and V_{DS2} respectively. The peak voltages of voltages V_{C1} , V_{DS1} and V_{DS2} are 363V, 536V and 515V respectively which agree with equations 14 and 16.

Figure 10. Voltage across C_1 (V_{C1}) waveform :scale (200V/Div.)Figure 11. Voltage across transistor (V_{Ds1}) waveform :Scale (200V/Div.)Figure12 .Voltage across transistor (V_{Ds2}) waveform: Scale(200V/Div.)

For the same modulation index and sun light intensity of 500W/m^2 , Fig.13 shows the voltage and current of PV panel. Fig.14 shows the dc output voltage of boost converter (V_{boost}) which its value at steady state is 167V with ripple less than 1%. The RMS value of output current of the inverter that is injected to grid is 1.09A. The power factor of output current with respect to grid voltage is 0.903 and total harmonic distortion (THD) factor of output current is 3.12%. Fig.15 shows the waveforms of inverter output current and grid voltage.

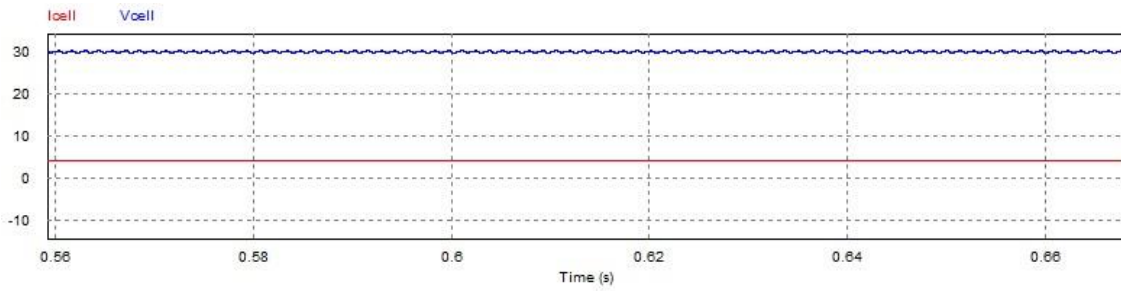

Figure 13. PV panel voltage (V_{cell}) and PV panel current (I_{cell}) against time: scale for voltage (10V/Div), scale for current (10A/Div).

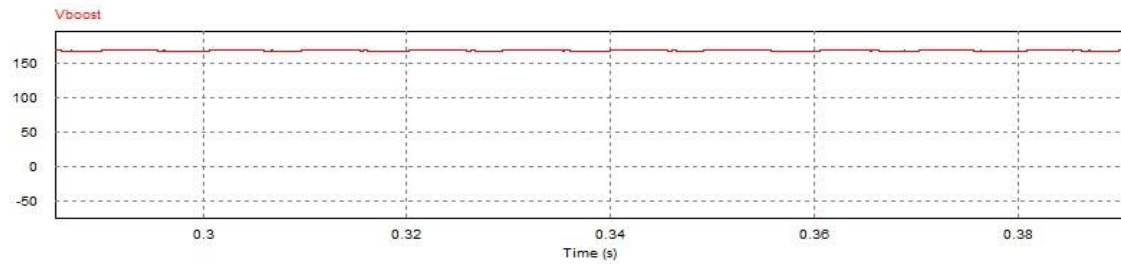

Figure 14. Output voltage of boost converter (V_{boost}) against time: scale (50V/Div.)

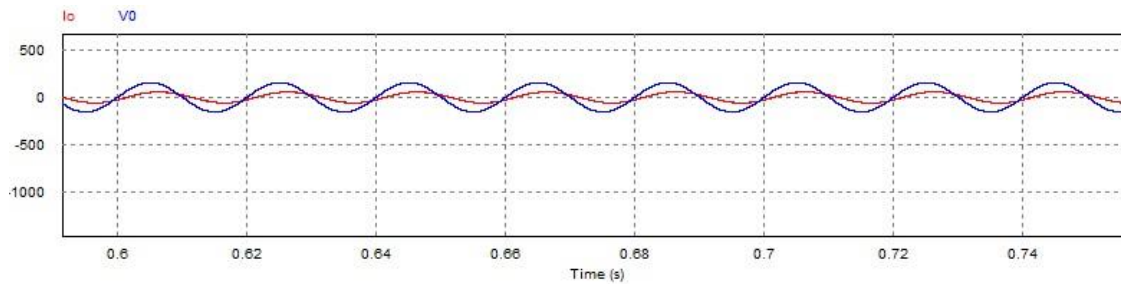

Figure 15. Output current (I_o) and grid voltage (V_o) waveforms: scale for voltage (200V/Div), scale of output current (10A/Div).

Figs. 16-18 show V_{C1} , V_{DS1} and V_{DS2} respectively with the same sun light intensity ($S=500W/m^2$). The peak values of these voltages are 341V, 511V and 514V respectively.

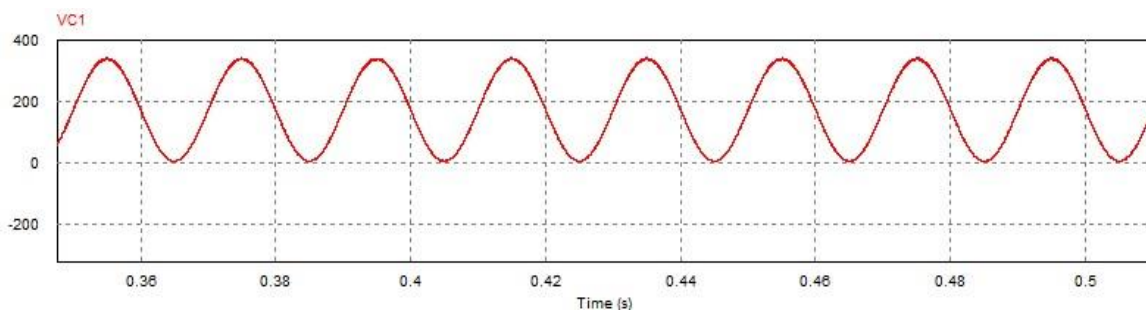

Figure 16. Voltage across C_1 (V_{C1}) waveform :scale (200V/Div).

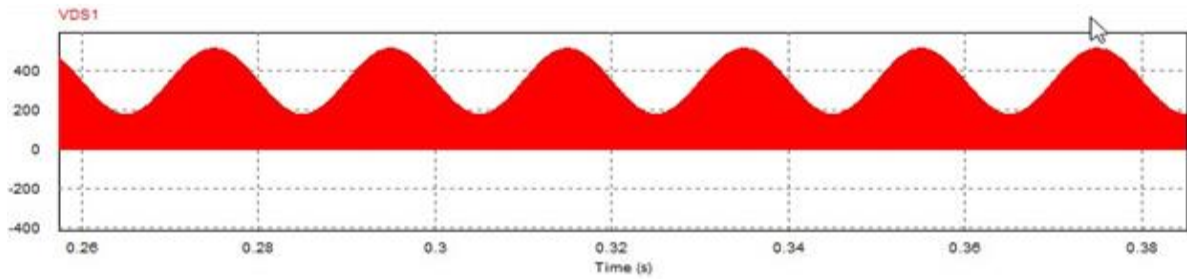

Figure17. Voltage across transistor (V_{DS1}) waveform :Scale (200V/Div.)

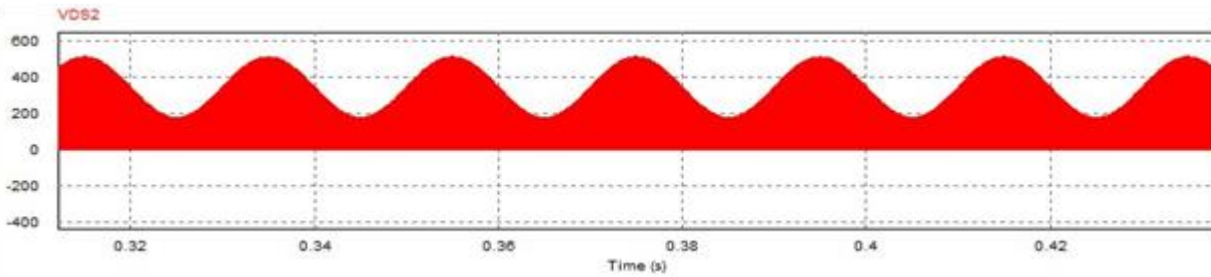

Figure18 .Voltage across transistor (V_{DS2}) waveform: Scale(200V/Div.)

Table 2 shows PV panel power at maximum power point (MPP), output power of the inverter (P_o) injected to grid ,THD% of inverter output current and complete system efficiency for different sunlight intensity .

Table 2 Different results with different sunlight intensity

$S(W/m^2)$	PV Panel Power(W)	$P_o(W)$	THD%	Efficiency($\eta\%$)
1000	236	213	2.69	90.2
800	189	171	2.72	90.4
600	142	130	2.83	91.5
500	118	110	3.12	93.2
300	70	66	3.4	94.3

4. Conclusion

A transformerless quasi-Z-source inverter topology is proposed in this paper. The input DC voltage of this type of z-source inverter is supplied from DC output voltage of DC-DC boost converter. The boost converter is suggested to obtain high DC voltage and to implement P&O algorithm for operation of PV panel at MPP. The complete

system is designed and power simulation (PSIM) software is used for simulation. Based on simulation results, the following aspects can be concluded:

- 1- Lower cost and higher efficiency DC-AC conversion due to use two active switches in the quasi-Z-source inverter compared with the traditional single-phase full-bridge inverters and z-source inverters where four active switches are used.
- 2-Light weight due to the operation of complete system with single ground (no isolation transformer is used).
- 3-Sinusoidal current injected into the grid with low total harmonic distortion (THD) factor irrespective to the variation of PV extracted power .

5. References

1. Tofael Ahmed, Saad Mekhilef, (2015). Semi-Z-source inverter topology for grid-connected photovoltaic system .IET Power Electron.,Vol.8, iss.1, pp.63-75.
2. Araujo, S.V., Zacharias, P., Mallwitz, R. (2010).Highly efficient single-phase transformerless inverters for grid-connected photovoltaic systems. IEEE Trans. Ind. Electron., Vol.57,No.9, pp.3118-3128.
- 3.Lopez, O., Freijedo, F.D., Yepes, A.G., Pablo Fern´andez-Comesa˜na, Jano Malvar, Remus Teodorescu, Jes´us Doval-Gandoy,(2010).Eliminating ground current in a transformerless photovoltaic application. IEEE Trans. Energy Convers., Vol.25,No.1, pp.140-147.
4. H. Xiao, X. Liu, and K. Lan,(2014). Optimised full-bridge transformerless photovoltaic grid-connected inverter with low conduction loss and low leakage current . IET Power Electronics, vol. 7, pp. 1008-1015.
5. B. Yang, W. H. Li, Y. J. Gu, W. F. Cui, and X. N. He, (2012). Improved Transformerless Inverter With Common-Mode Leakage Current Elimination for a Photovoltaic Grid-Connected Power System. IEEE Transactions on Power Electronics, vol. 27, pp. 752-762 .
6. F. Zhang, S. Yang, F. Z. Peng, and Z. Qian, "A zigzag cascaded multilevel inverter topology with self voltage balancing,(2008). " in Twenty-Third Annual IEEE Applied Power Electronics Conference and Exposition, pp. 1632-1635.
7. Y. FANG and X. MA,(2010). A Novel PV Microinverter With Coupled Inductors and Double-Boost Topology. IEEE transactions on power electronics, vol. 25,pp. 3138-3146.
8. Y. Berkovich and B. Axelrod, (2011). Switched-coupled inductor cell for DC–DC converters with very large conversion ratio . IET power electronics, vol. 4, pp. 309-315.
9. G. Y. Zhu, B. A. McDonald, and K. R. Wang,(2011).Modeling and Analysis of Coupled Inductors in Power Converters . *IEEE Transactions on Power Electronics*, vol. 26, pp. 1355-1363.
10. Y. Zhou, W. Huang, P. Zhao, and J. Zhao,(2014). Coupled-inductor single-stage boost inverter for grid-connected photovoltaic system . IET Power Electronics, vol. 7, pp. 259-270.

11. Tofael Ahmed, Tey Kok Soon and Saad Mekhilef, (2014). A Single Phase Doubly Grounded Semi-Z-Source Inverter for Photovoltaic (PV) Systems with Maximum Power Point Tracking(MPPT). Vol.7, pp. 3618-3641.
12. N. Femia, G. Petrone, G. Spagnuolo, and M. Vitelli, (2005). Optimization of Perturb and Observe Maximum Power Point Tracking Method. IEEE Transaction on Industrial Electronics, vol. 20, no.4, pp. 963-973.
13. A. M. Atallah, A. Y. Abdelaziz, R. S. Jumaah,(2014). Implementation of Perturb and Observe MPPT of PV System with Direct Control Method Using Buck and Buck-BOOST Converter. Emerging Trends in Electrical, Electronics Instrumentation Engineering: An international Journal, vol.1, no.1, pp.31-44.
14. S. Jain, A. Vaibhav, and L. goyal, (2014). "Comparative Analysis of MPPT Techniques for PV in Domestic Applications". 6th IEEE Power India International Conference (PIICON), pp. 1-6, Delhi .
15. S. Alsadi and B. Alsayid, (2012). Maximum Power Point Tracking Simulation for Photovoltaic Systems Using Perturb and Observe Algorithm, (2012). International Journal of Engineering and Innovative Technology(IJEIT), vol. 2, no.6, pp. 80-85.
16. T. P. Sahu, T. V. Dixit, and R. Kumar, (2014). Simulation and Analysis of Perturb and Observe MPPT Algorithm for PV Array Using CUK Converter. Advance in Electronic and Electric Engineering, vol. 4, no. 2, pp. 213-224.
17. D. Cao and F. Z. Peng, (2009). "A family of Z-source and quasi-Z-source DC-DC converters," in Twenty-Fourth Annual IEEE Applied Power Electronics Conference and Exposition, pp. 1097-1101.
18. D. Cao, S. Jiang, X. Yu, and F. Z. Peng, (2011). Low-Cost Semi-Z-source Inverter for Single-Phase Photovoltaic Systems . IEEE Transactions on Power Electronics, vol. 26, pp. 3514-3523.