

## **Linear Analysis of Composite Steel Ribbed Deck by Grillage Method**

**Prof. Dr. Husain M. Husain**

Civil Engineering Dept., College of Engineering  
University of Tikrit, Salah Al-Deen, Iraq

**Dr. Sa'ad Kh. M. Al-Hadithy**

Civil Engineering Dept., College of Engineering  
Al-Mustansiriya University, Baghdad, Iraq

### **Abstract**

*This work is aimed to study the behaviour of composite top steel cover plate on steel beams running in two directions. Linear shear connection behaviour with partial interaction is assumed. The study assesses the effect of slip that will take place between cover steel plate and the steel beams when the composite deck is subjected to normal loads.*

*The simplified grillage (or grid-framework) method is used to study the deflections and the moments in the grillage caused by the applied loads. The solution is approximate but gives acceptable accuracy when compared with more accurate methods such as the method of finite elements by using plane shell elements.*

**Keywords:** Composite deck, Grillage method, Shear connectors, Steel structure.

### **الخلاصة**

الدراسة الحالية تهتم بسلوك المنشآت المركبة من صفيحة عليا مربوطة إلى عتبات حديدية سارية باتجاهين أخذة بنظر الاعتبار السلوك الخطي لروابط القص مع التداخل الجزئي. وقد تم استخدام طريقة المشبكات كطريقة مبسطة لدراسة الهطول والعزوم الناتجة عن الأحمال المسلسلة. الطريقة المقترحة تقريبية لكن تعطي دقة مقبولة بالمقارنة مع طرق دقيقة أكثر مثل طريقة العناصر المحددة. كلمات دالة: الارضيات المركبة، طريقة المشبكات، روابط القص، منشأ حديدي.

## 1. Introduction

A composite structure consists of two or more structural components of the same or different materials. The main aim of using a composite structure is to make full use of the beneficial properties of the different components.

The present work is concerned with the behaviour of a composite deck made up of a top cover plate connected to steel beams in two directions by taking into consideration the linear action of shear connection in the force-slip relationship. The grillage (or grid framework) method as a simplified method of analysis is used in this study. In the grillage analogy, these types of composite structures are represented by an assemblage of rigidly interconnected composite beams in bending and torsion. These grillage beams form a grid surface with three degrees of freedom at each connection node (two rotations about axes in the plane of the grillage and one deflection normal to this plane). A method is suggested to derive the required section rigidities (the flexural and torsional rigidities) of the grillage members from the composite action of the individual grillage composite members.

## 2. Grillage Method

In grillage (or grid-framework) analogy, there are three unknown displacements to be considered at each connection node; a vertical displacement ( $w$ ) normal to the plane of the grillage, and two rotations ( $\theta_x$ ) and ( $\theta_y$ ) about mutually perpendicular axes lying in the grillage plane. The grillage is assumed to be in a 2-dimensional plane and displacements in the plane of the grillage are ignored. As a result, the drilling rotation ( $\theta_z$ ) about the axis normal to the grillage plane is also ignored.

The total stiffness matrix may be constructed by expressing the nodal forces  $V$ ,  $M_x$  and  $M_y$  in terms of the corresponding nodal displacements  $w$ ,  $\theta_x$  and  $\theta_y$  respectively, by assembling the member stiffnesses (superposition of structures consisting of one member at a time<sup>[1]</sup>) **Fig.(1)**.

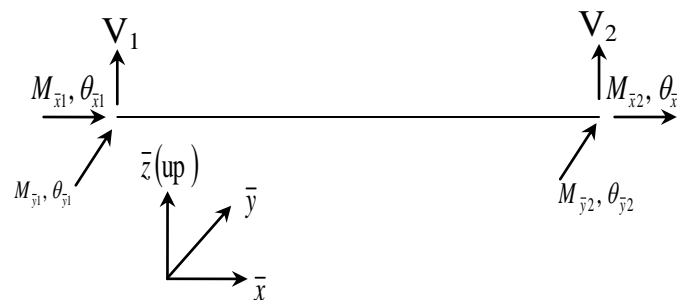

**Figure (1) Grillage beams in local coordinates**

### 3. Derivation of the Stiffness Matrix for Grillage Member

For a grillage prismatic member, the bending stiffnesses are of the type  $(\frac{4EI}{L})$ ,  $(\frac{2EI}{L})$ , etc..., and the twisting stiffnesses are usually taken from St. Venant theory and they are of the type  $(\frac{GJ}{L})$  when warping of the sections is assumed unrestrained. If the section is restrained against warping, then  $J$  is modified as it will be discussed.

For deriving the stiffness matrices, the strain energy method is used. For a linear elastic body, the strain energy is:

$$U = \frac{1}{2} \int_{vol} [\sigma_x \epsilon_x + \sigma_y \epsilon_y + \tau_{xy} \gamma_{xy} + \tau_{xz} \gamma_{xz} + \tau_{yz} \gamma_{yz}] d(vol) \dots\dots\dots (1)$$

as  $\epsilon_z$  is assumed zero in beams

Applying Castigliano’s second theorem (the derivation of strain energy with respect to a force (or couple) is equal to the displacement (or rotation) of the force (or couple)), the stiffness matrix in local coordinates for the beam shown in **Figs.(1)** and **(2)** is given by including the transverse shear effects as:

$$\begin{Bmatrix} M_{\bar{x}1} \\ M_{\bar{y}1} \\ V_1 \\ M_{\bar{x}2} \\ M_{\bar{y}2} \\ V_2 \end{Bmatrix} = \begin{bmatrix} a_1 & 0 & 0 & -a_1 & 0 & 0 \\ 0 & a_3 & a_2 & 0 & a_4 & -a_2 \\ 0 & a_2 & a_5 & 0 & a_2 & a_5 \\ -a_1 & 0 & 0 & a_1 & 0 & 0 \\ 0 & a_4 & a_2 & 0 & a_3 & -a_2 \\ 0 & -a_2 & a_5 & 0 & -a_2 & a_5 \end{bmatrix} \begin{Bmatrix} \theta_{\bar{x}1} \\ \theta_{\bar{y}1} \\ w_1 \\ \theta_{\bar{x}2} \\ \theta_{\bar{y}2} \\ w_2 \end{Bmatrix} \dots\dots\dots (2)$$

where:

$$a_1 = \frac{GJ}{L}, \quad a_2 = \frac{6EI_{\bar{y}}}{L^2} \frac{1}{1+g}, \quad a_3 = \frac{4EI_{\bar{y}}}{L} \frac{4+g}{4(1+g)}, \quad a_4 = \frac{2EI_{\bar{y}}}{L} \frac{2-g}{2(1+g)}, \quad a_5 = \frac{12EI_{\bar{y}}}{L^3} \frac{1}{1+g} \quad \text{and}$$

$g = \frac{12fEI_{\bar{y}}}{GA_v L^2}$  is a factor for transverse shear deflection, and  $A_v$  is the effective shear area

( $A_v = \alpha_v A$ ). Here  $f$  is shear shape factor or  $(\frac{1}{f})$  is shear area correction factor and it is

approximately equal (1.0) for I-sections. This is defined as the ratio of the exact shear strain energy to that calculated by assuming constant average shear stress [2]. Warping restraint

affect can also be including in the torsional stiffness  $\frac{GJ}{L}$ .

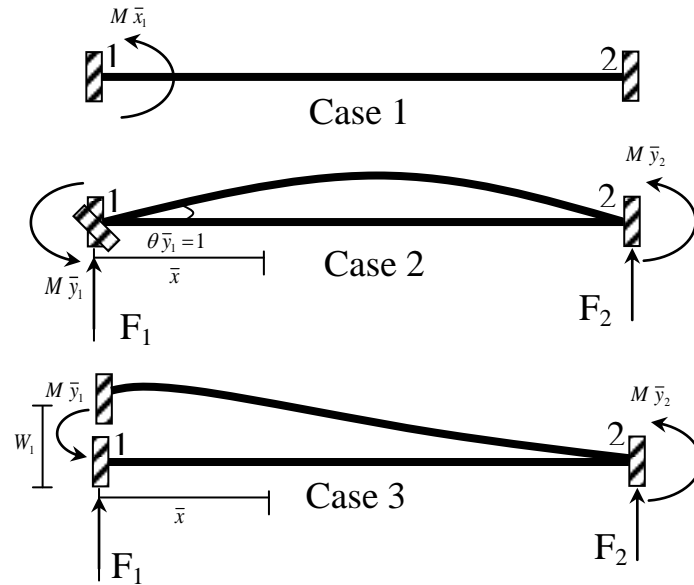

Figure (2) Beam (1-2) with different acting generalized forces

#### 4. Evaluation of Elastic Section

##### 4-1 Rigidities of Grillage Members

The elastic rigidities of the grillage members should be derived from the section properties of the actual composite slab-beam structure so that an adequate picture for the composite section behaviour under the applied loading can be obtained from the equivalent grillage.

The elastic section rigidities required for the sections of the equivalent composite grillage members are as follows:

- ❶ Bending (or Flexural) Rigidity (EI).
- ❷ Torsional Rigidity (GJ).
- ❸ Shearing Rigidity (GA<sub>v</sub>).

##### 4-1-1 Flexural Rigidity (EI)

A large number of research studies <sup>[3,4,5,6]</sup> have been devoted to calculate the deflections of composite beams with partial shear interaction. The final form of the solution of the governing equation for a composite beam has been stated in following equation, as:

$$w = w_s + \frac{C_{12}}{E_2 C_1 \sum I_{it}} F \dots\dots\dots (3)$$

where F is the induced axial force in the top plate (component 1) and equally but oppositely in the bottom steel beam (component 2). F is given by the solution of the following equation:

$$\frac{d^2F}{dx^2} - C_1F = -C_2M \dots\dots\dots (4)$$

where:

$$C_1 = \frac{K_{co}n}{P_{co}} \left( \left( \frac{1}{E_1'A_1} + \frac{1}{E_2A_2} \right) + \frac{C_{12}^2}{E_1'I_1 + E_2I_2} \right)$$

$$C_2 = \frac{K_{co}n}{P_{co}} \frac{C_{12}}{E_1'I_1 + E_2I_2}$$

$$C_{12} = \frac{h_1 + h_2}{2}$$

$$\sum I_{it} = I_{1t} + I_2$$

$I_{1t}$  = moment of inertia of transformed area of component 1,

$$I_{1t} = \frac{E_1'}{E_2} I_1$$

$E_1' = \frac{E_1}{(1 - \nu_1^2)}$  = modulus of elasticity of laterally confined top plate.

$E_1$  = modulus of elasticity of cover plate.

$\nu_1$  = Poisson's ratio for cover plate.

$E_2$  = modulus of elasticity of steel beams.

$I_1$  = moment of inertia of cover plate about its own centroid.

$I_2$  = moment of inertia of steel beam about its own centroid.

$K_{co}$  = normal modulus of shear connection.

$n$  = number of shear connectors in the cross-section.

$P_{co}$  = longitudinal spacing of connectors

$h_1$  = thickness of the upper component **Fig.(3)**.

$h_2$  = thickness of lower component **Fig.(3)**.

The solution of these two equations (3 and 4) may be found for simply supported beams under different loading cases. The solution submitted by Jasim [7] by using Fourier series will be adopted in the present study to calculate the flexural rigidity of the composite sections.

For the case of a point load at mid-span of a simply supported beam, **Fig.(4)**, the solution for the maximum deflection is:

$$\frac{w_p}{w_f} = 1 + \frac{3C_*}{K^2} \left( 1 - \frac{1}{K} \tanh K \right) \dots\dots\dots (5)$$

$$w_f = \frac{PL^3}{48E_2I}$$

where:

$EI_f$  = flexural rigidity of the composite beam with full interaction.

$$C_* = \left( \frac{(h_1 + h_2)^2}{4(E_1 I_1 + E_2 I_2)} \right) \left( \frac{E_1' A_1 E_2 A_2}{(E_1' A_1 + E_2 A_2)} \right)$$

By using the equation:  $\frac{w_p}{w_f} = \frac{EI_f}{EI_p}$  then:

$$\frac{EI_f}{EI_p} = 1 + \frac{3C_*}{K^2} \left( 1 - \frac{1}{K} \tanh K \right) \dots\dots\dots (6)$$

Using the notation:

$$D_2 = \frac{3C_*}{K^2} \left( 1 - \frac{1}{K} \tanh K \right)$$

Eq. (6) reduces to:

$$EI_p = \frac{EI_f}{(1 + D_2)} \dots\dots\dots (7)$$

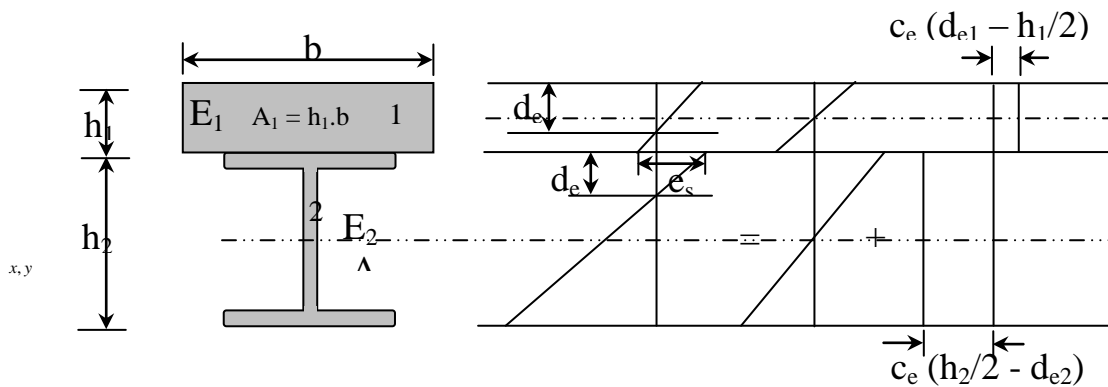

Figure (3) Strain distribution for partial interaction

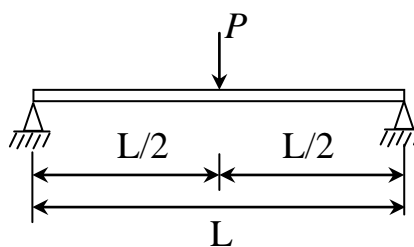

Figure (4) Simply supported beam (central point load)

**4-1-2 Torsional Rigidity**

The upper part of the composite section is divided into three portions, two equal cover plate portions of dimensions  $(b_{ce} \times h_1)$  and a central composite portion of dimensions  $(b_s \times (h_1 + t_f))$ , as shown in **Figs.(5)** and **(6)**. The torsional stiffness of the upper part may then be estimated from the following equation. For the interior composite beam <sup>[8]</sup>:

$$G_{TP}J_{TP} = \frac{1}{\beta_2} \left[ 2b_{ce}h_1^3G_1 + b_s(h_1 + t_f)^3 \cdot G_{eq} \right] \dots\dots\dots (8)$$

and for the edge beam:

$$G_{TP}J_{TP} = \frac{1}{\beta_2} \left[ b_{ce}h_1^3G_1 + b_s(h_1 + t_f)^3 \cdot G_{eq} \right] \dots\dots\dots (9)$$

where:

$\beta_2$  = a coefficient which is a function of  $(\frac{b}{a})$  <sup>[9]</sup>.

b = longer dimension of the rectangular cross-section.

a = shorter dimension of the rectangular cross-section.

$$G_{eq} = \frac{E_{eq}}{2(1 + \nu_{eq})}$$

$E_{eq}$  = equivalent modulus of elasticity of central portion of the upper part of the composite

section,  $E_{eq} = \frac{E_1h_1 + E_2t_2}{h_1 + h_2}$

$\nu_{eq}$  = equivalent Poisson's ratio of central portion of the upper part

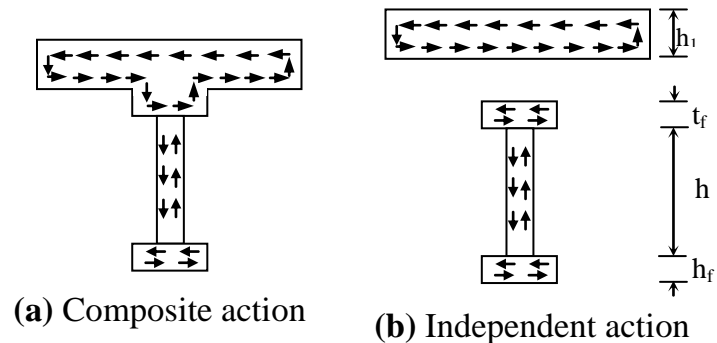

**Figure (5) Shear stress flow in composite sections**

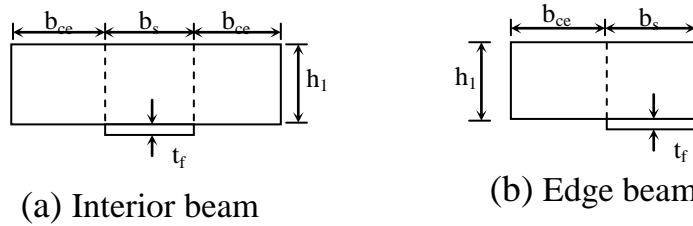

Figure (6) Evaluation of stiffness for the upper part division

The torsional stiffness of the lower part may be estimated as follows [8]:

a) *Free to Warp:*

$$G_s J_{sd} = \frac{1}{3} (b_s t_f^3 + h t_w^3) G_2 \dots\dots\dots (10)$$

b) *Warping Prevented (or Restrained):*

$$G_s J'_{sd} = J'_s G_2 - \frac{1}{3} b_s t_f^3 G_2 \dots\dots\dots (11)$$

Here,

$$J'_s = \frac{TL}{G_2 \phi_m}, \text{ where } T = \text{applied torque, } L = \text{length of the beam and}$$

$\phi_m$  = total angle of rotation when the end of beam are fixed, (in radian).

$$\phi_m = \frac{T}{C_w E_2 \beta_1^3} \left( \beta_1 L - 2 \tanh \frac{\beta_1 L}{2} \right) \beta_1 = \left( \frac{J_s G_2}{C_w E_2} \right)^{\frac{1}{2}}, \quad C_w = \frac{t_f b_s^3 (h + t_f)^2}{24} = \text{Warping constant}$$

In this work, the case of warping being prevented will be used, and the torsional rigidity of a composite section can be calculated from the following equation:

$$GJ_p = G_{Tp} J_{Tp} + G_2 J'_{sd} \dots\dots\dots (12)$$

This hypothesis gives an experimental to a theoretical ratio of (0.95) [10]

**4-1-3 Shearing Rigidity**

In the present work, the transverse shearing rigidity for a composite member will be computed by two methods as follows:

1. Shearing rigidity for the steel component only by calculating the shear area for the steel web, Fig.(7a), and it can be stated as:

$$GA_v = G_2 t_w h_2 \dots\dots\dots (13)$$



2. Shearing rigidity for the top cover plate and steel components together because the depth of cover top plate may take into account the shear area especially when it is not small. Recognizing that the transformed section concept can be applied to the steel web as shown in **Fig.(7b)**, thus this method can be stated as:

$$GA_v = G_2 \left( \frac{E_2 t_w}{E_1} \right) (h_1 + h_2) \dots\dots\dots (14)$$

where:

$t_w$  : Thickness of steel web.

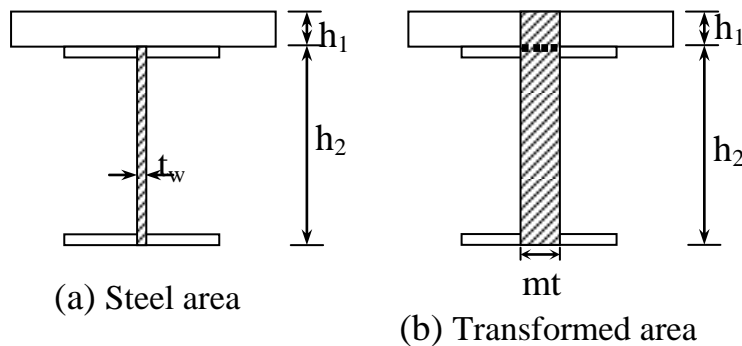

**Figure (7) Transverse shearing rigidity**

### 5. Application

A rather half scale single-span two-lane composite steel ribbed deck of 3.05m in span and 2.29m in width is considered. The cover plate is 4mm thick and designed for  $F_y=245$  MPa. The steel framework consists of five longitudinal beams connected by I-diaphragms at two ends, mid-span, and at the quarter-spans. All beams are of section W6×15, G40.21-44W steel [2]. The numbers of studs were determined on the basis of fatigue requirements [11]. Other notations are explained in **Fig.(8)**. The composite ribbed deck is analyzed for the following load cases:

1. Load case A (central point load of 100kN at node 13) (for showing bending effect).
2. Load case B (edge point load of 100kN at node 3) (for showing twisting effect).

The composite deck is also analyzed for the following mesh geometry:

1. Without shearing area rigidity (case1).
2. With transformed shearing area (case2).
3. With steel girder shear area only (case3).

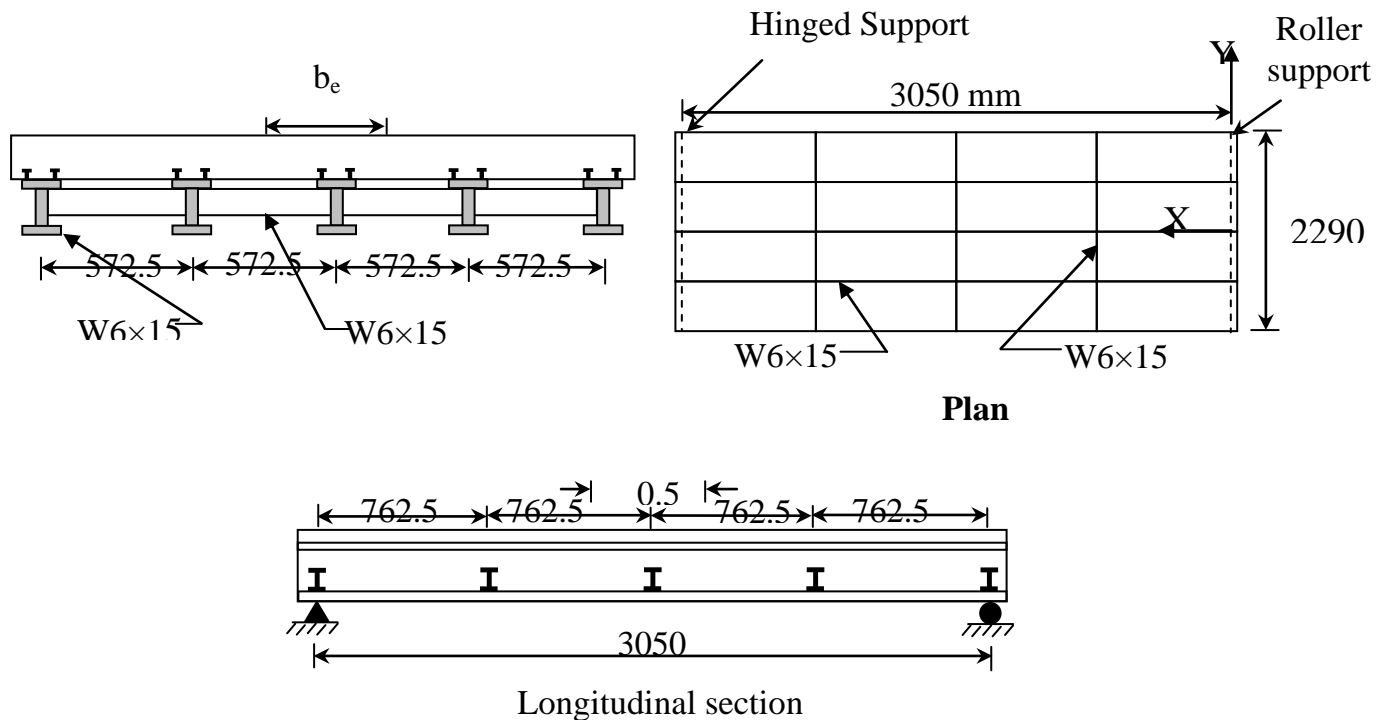

Figure (8) Geometric details of the example

## 6. Conclusions

The evaluation of the applicability, limitation, accuracy and economy of the grillage analysis has been the concern of the present work. This was achieved through a comparison with other commonly used but rather sophisticated solution technique, namely, the finite element method (using the three dimensional flat shell elements). This example is analyzed by the grillage technique and the results are compared with the results obtained by the Finite elements. The study of the results leads to a number of conclusions. These are presented herein:

1. Bridge composite steel ribbed decks can be analyzed by the grillage beams with combined flexural and torsional rigidities. The resulting deflections and moments are usually in acceptable agreement with the results of the three dimensional plane (or flat) shell elements in the three dimensional finite element method.
2. Effectiveness of shear lag phenomenon is very small in the examples of the present study and it is found that the effective flange width is approximately equal to the actual flange width.
3. Accuracy of the grillage analysis is sensitive to the magnitude of the flexural inertias of the grillage members as these usually dominate the structural behaviour of the deck.
4. The grillage analysis of the composite ribbed decks in present study, the shear area can be ignored without affecting the accuracy of the results.

5. Taking the warping restraint effect into consideration, the deflections and moments results were not much affected.
6. Comparison of the results of deflections and moments indicates that the employed solution technique yielded close values in their results with a maximum deviation of 15% for the moments and 13% for deflections.

**Table (1) Effect of mesh geometry**

<i>Type of Loading</i>	<i>Mesh Geometry</i>					
	<i>Case1<sup>1</sup></i>		<i>Case2<sup>2</sup></i>		<i>Case3<sup>3</sup></i>	
	<i>W<sup>4</sup></i>	<i>M<sup>5</sup></i>	<i>W</i>	<i>M</i>	<i>W</i>	<i>M</i>
<b>A</b>	1.976	0.59	1.881	0.58	1.813	0.61
<b>B</b>	4.192	0.78	4.21	0.79	4.221	0.81

Grillage mesh without shearing area rigidity.

<sup>2</sup> Grillage mesh with transformed shearing area rigidity.

<sup>3</sup> Grillage mesh with steel beam shearing area rigidity.

<sup>4</sup> Deflection of the deck beneath the point load (mm).

<sup>5</sup> Moment of the deck beneath the node number 8, (kN.m/m).

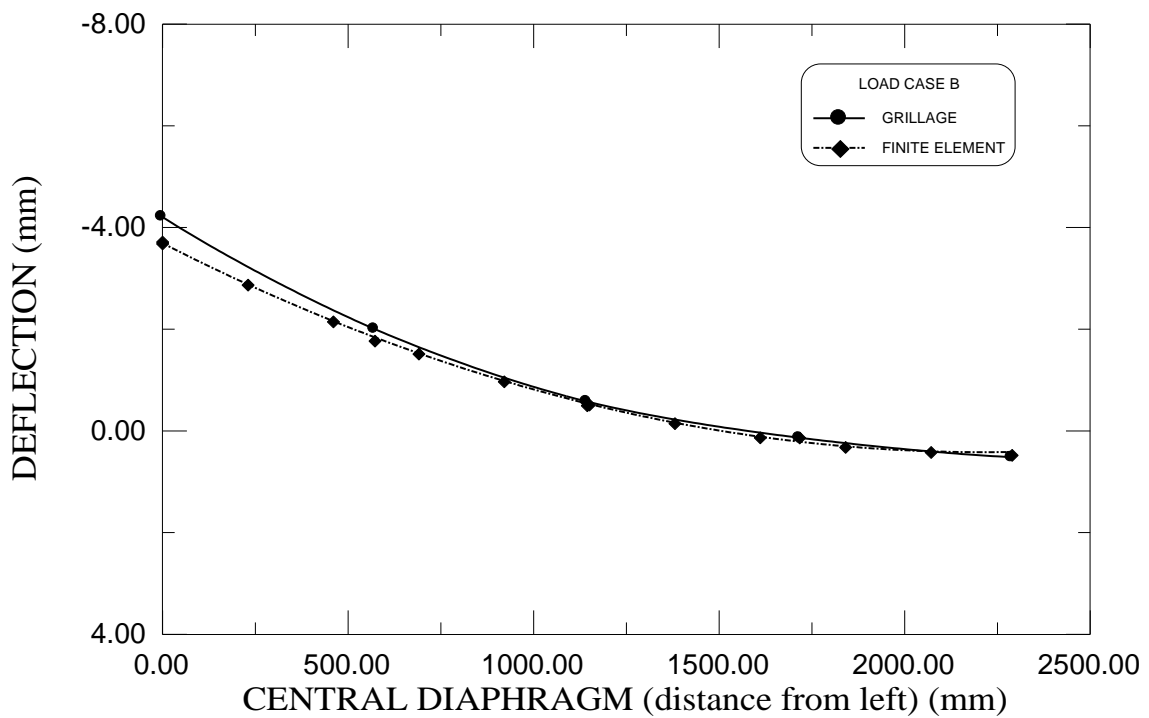
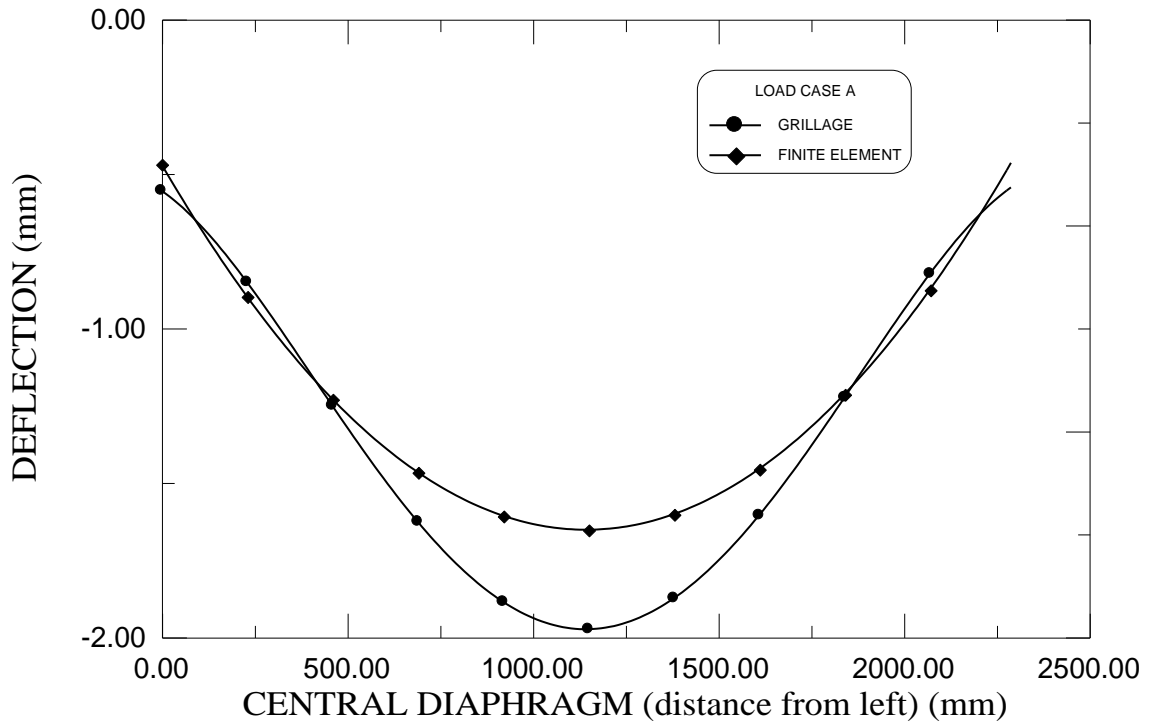

Figure (9) Comparison of deflection results obtained by different techniques (Load Case A and B)

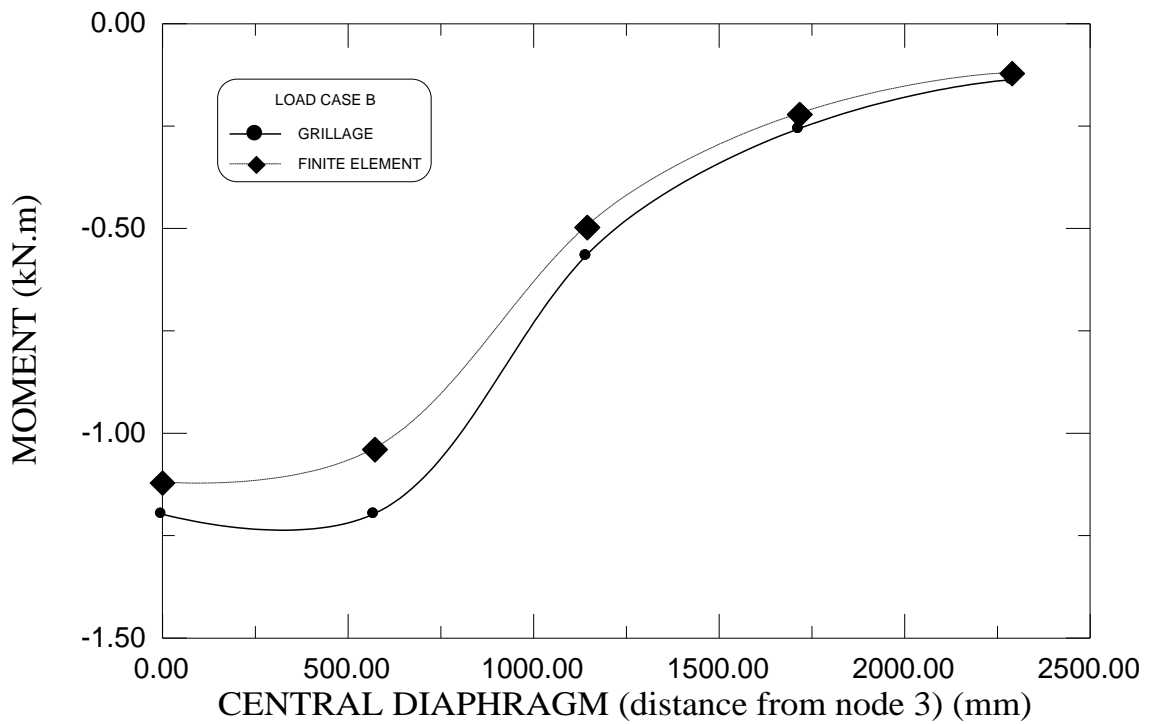
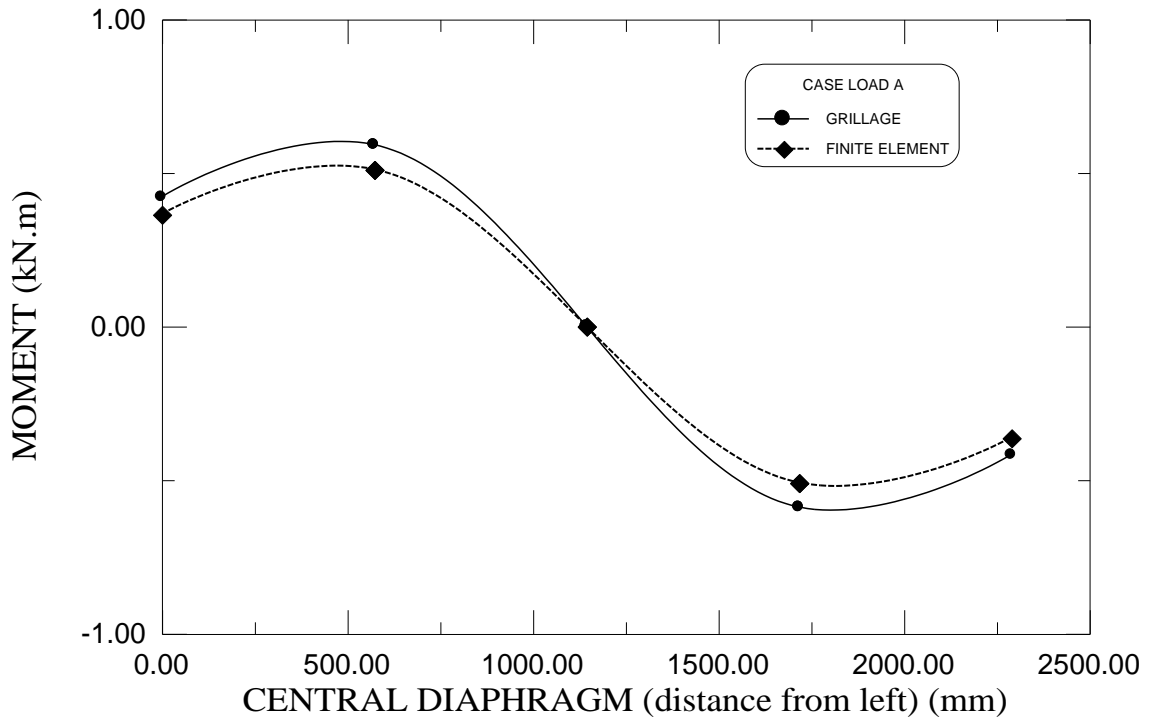

Figure (10) Comparison of moment results obtained by different techniques (Load Case A and B)

## 7. References

1. Yettram, A. L., and Husain, H. M., "*Duality of Matrix Force and Displacement Methods of Linear Structural Analysis*", AIAA Journal, American Institute of Aeronautics and Astronautics, June 1965.
2. Gere, J. M., and Weaver, W., "*Analysis of Framed Structures*", Van Nostrand, 1965.
3. Jasim, N. A., "*Deflections of Partially Composite Beams with Linear Connector Density*", Accepted for Publication in Journal of Constructional Steel Research, U.S.A., 1998.
4. Jha, B. N., "*Design of Shear Connectors for Composite Beams for Static Loads*", Journal of Structural Engineering, Vol. 6, No. 2, July 1978, pp. 102-107.
5. Karim, A. A., "*The Effect of Partial Shear Connection on the Behaviour of Continuous Beams*", M.Sc. Thesis, University of Basrah, Iraq, 1996.
6. Johnson, R. P., and Molenstra, N., "*Partial Shear Connection in Composite Beams for Buildings*", Proceedings of the Institution of Civil Engineers, Part 2, Vol. 91, December 1991, pp. 679-704.
7. Jasim, N. A., "*The Effect of Partial Interaction on Behaviour of Composite Beams*", Ph.D. Thesis, University of Basrah, Iraq, 1994.
8. Hassan, F. M., and Kadhum, D. A. R., "*Behaviour and Analysis of Composite Sections under Pure Torsion*", Engineering and Technology, Scientific Journal Published by the University of Technology, Baghdad, Iraq, Vol. 7, No. 1, 1989, pp. 67-97.
9. Popov, E. P., "*Mechanics of Materials*", Second Edition, SI Version, Prentice-Hall International Editions, 1978.
10. Frodin, J. G., Taylor, R., and Stark, J. W., "*A Comparison of Deflection in Composite Beams Having Full and Partial Shear Connection*", Proceedings of Institution of Civil Engineers, Part 2, Vol. 41, June 1978, pp. 307-322.
11. Ontario Highway Bridge Design Code, Ministry of Transportation and Communication, Ontario, Canada, 1983.

## Notations

- $A_i$  Cross-sectional area of part (i) (i is 1 or 2).
- $b_{ce}$  Width of side portion of upper part.
- $b_s$  Width of central portion of upper part, or width of flange of steel I-section.
- $EI_p$  Bending (or flexural) rigidity of composite beam with partial shear connection.
- $I_i$  Moment of inertia of part (i) (i is 1 or 2).
- i Subscript that refers to the part or component.
- $A_v$  Shear area (gross area of web).
- V Shear force or point force at a grillage node.
- $x', y'$  Local rectangular axes.
- $x, y$  Global rectangular axes.