

## Design and Implementation of Modern Security System Based on Mobile Phone

*Assist. Lecturer*                      *Assist. Lecturer*                      *Assist. Lecturer*  
*Ammar Hussein Mutlak,*              *Siraj Qays Mahdi,*                      *Omar Nameer M. Salim*  
*Electrical and Electronic*              *Electrical and Electronic*              *Electrical and Electronic*  
*Technical College*                      *Technical College*                      *Technical College*  
*ammam\_alqiesy@yahoo.com,*      *siraj\_qays@yahoo.com,*              *omar\_namer2005@yahoo.com*

### Abstract

*The work presented in this paper intended to design and implement a new security system which can be used to protect important places by calling the place owner through a mobile phone to indicate him that the protected place is impenetrable. The system consists of five hardware parts: sensing system (laser circuit and control circuit), Digital Video Recorder (DVR) system, calling circuit, delay and ignition circuit and reset circuit. The Laser circuit of the sensing system connected with the control circuit to detect unauthorized intruder and motivating control circuit. The control circuit which used PIC 18F452 as a major part in its operation is response for controlling and activation the calling circuit and DVR. Where, DVR is used for monitoring protected places and recording the important events. While the calling circuit is used to establish calling with the remote mobile. Ignition circuit is employed to make delay and renew the ignition signal to continue activation the calling process. When need to reset the system, reset circuit utilizes for stopping the calling and reset the microcontroller to complete the function of security system. The mechanism of calling circuit depends on the speed dialing technique in mobile phone by saving the number of the owner in the key no. 2 of the mobile phone device. The novel work was implemented to make it more reliable system than other security system by its possibility for warning the owner in far-away places and recording the events.*

*Keywords: security, laser system, PIC microcontroller, camera system and mobile phone.*

*تصميم وتنفيذ نظام امني حديث مستند على الهاتف المتنقل*

*الخلاصة*

*العمل المقدم في هذا البحث يهتم بتصميم نظام امني حديث للحماية, لحماية الأماكن المهمة من خلال الاتصال بصاحب المكان بواسطة الهاتف النقال لأعلامه بأن المكان المحمي تم اختراقه. يتألف النظام من خمسة أجزاء: نظام*

الاستشعار ( دائرة الليزر ودائرة السيطرة), دائرة الاتصال, دائرة التصفير, ودائرة التأخير والقدح. دائرة الليزر لنظام الاستشعار تكون متصلة بدائرة السيطرة لكشف الدخلاء وتحفيز دائرة السيطرة. دائرة السيطرة تستخدم PIC18F452 كجزء أساسي في عملياته ليستجيب للسيطرة وتحفيز دائرة الاتصال ودائرة التسجيل الرقمية والتي تستخدم لمتابعة وتسجيل الأحداث المهمة . إن دائرة الاتصال تكون مسنولة عن لاتصال بهاتف المالك. دائرة القدح تستخدم لعمل تأخير زمني ويصار بعده إلى توليد إشارة القدح لإعادة عملية الاتصال مجددا. يتم استخدام دائرة الفصل أو التصفير لإيقاف عملية التنبيه والعودة بالنظام إلى وضعية الاستشعار لإكمال الوظائف الخاصة بنظام الحماية. آلية الاتصال تعتمد على تقنية الاتصال السريع في الهاتف النقال من خلال حفظ الرقم المخصص للمالك في مفتاح رقم 2 في جهاز الهاتف المتنقل. العمل المبتكر تم تنفيذه ليكون نظام موثوق أكثر من الأنظمة الأمنية الأخرى بإمكانيته تحذير المالك عند وجوده في الأماكن البعيدة وتسجيله للأحداث.  
كلمات الدلالة : الأمنية ، نظام الليزر، المسيطر الدقيق ، نظام التصوير، الهاتف الجوال.

## 1. Introduction

Security systems in our days became important for many applications which need a secret and these systems available with many modern features. Thieves tend to steal the expensive and important things while the owners are away or far away [1]. Many security systems available in market are not efficient to deal with the intruders. As for many security systems, loss from robbery and if the criminal got away, it invites unconfident of security reputation. Furthermore, it is crucial to has advanced alarm system which could not only secure, but also increase the chance to capture the criminal [2, 3].

Despite the different options available for increasing system security, mobile devices are suffering from inadequate protection, and they become targets for malicious attacks [4].

More and more functionality is incorporated into mobile phones. Mobile phones have become prevailing, while house and property security demands are continually increasing, the integration of the mobile phone and a surveillance system becomes more meaningful so that people can know the security of their properties anytime, anywhere [5].

Mobile phones are at present, quite ubiquitous and increasingly sophisticated. A mobile phone can not only be treated as a communication unit and accept phone calls. SMS, MMS, but now even e-mails can be sent or received a camera, a music box, a game platform, or even a wireless remote controller, since so many services are provided on a mobile phone. So in particular, new applications may achieve such as security and controller [5].

The design of security systems has been an important topic in order to implement large scale for alarming system. Therefore, many researches were introduced to design different type of security system according to the needed and the new revolution in technology.

Jiwa A., [6] present the design of mobile controlled car security system. The system is able to notify the car owner immediately when intrusion is detected. The design was based on GSM position, PIR sensor and LED's indicator in addition to mobile phone.

Liao Y., et. al. [7], proposes a mobile phone integrated alarming-system, which has two models: mobile, fixed alarm ways. The Alarming information contains local sound, video and

GPS information. The system provides two ways of reading the alarming information: web ways and mobile alarming media player ways for instant checking or repeated watching.

Bing W., et. al. [8], present the design and implementation of a practical home security system (PHSS). This system realizes its mobile surveillance via mobile phones by the planted Java applet. The challenge is that PHSS works independently under the existing Internet Service Providers (ISP) and telecoms. End-users can monitor their home and properties anywhere and anytime on the screen through internet in mobile phone.

## 2. The security System

Taking in consideration the need of security, it has become very essential to design security systems which should be reliable effective and economical. There are different wireless security systems used to protect places from the intruder, some of them utilize radio frequency while others utilize lasers [9].

Security lasers systems could be visible or invisible. Laser security system can effectively protect everything from small apartments to large areas of property. Most laser security systems consist of two main parts: first part is the transmitter and the second part is the receiver. Some Laser security systems use to rely on connections wired to a keypad, requiring the customer to use special codes to arm and disarm the system while others can be turned on or off with a wireless remote. The basic sensing component of a modern laser security system is an infrared motion detector. An infrared motion detector works by using beams of infrared light to detect changes in the environment. Laser security systems have many advantages. They are simple to install and can be used effectively inside or outside the protected places. Indoors, the sensors utilize normal power outlets and telephone jackets; outdoors, the sensors can be hidden beneath plants and bushes and will not harm lawns or other vegetation. However, laser security systems can be prohibitively expensive [10].

## 3. Design The Proposed System

The purpose of this work is to build a security system capable of protecting important places efficiently such as home, office, car, etc... This leads to design a multi stage modern security system which harmonizes between laser system principle and wireless communication system as shown in Fig. (1).

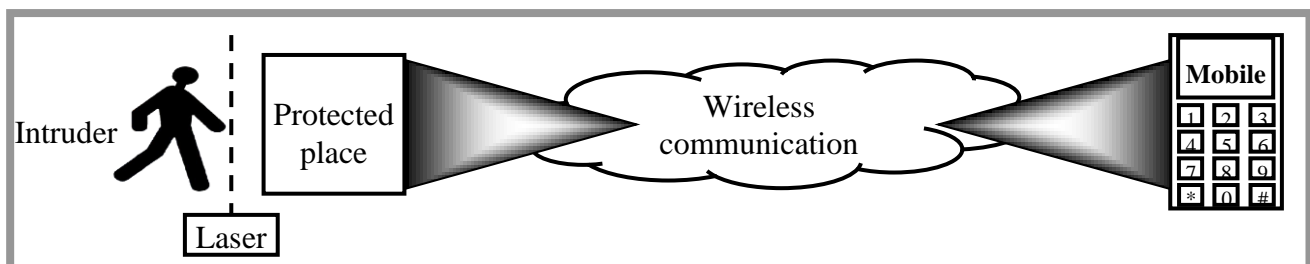
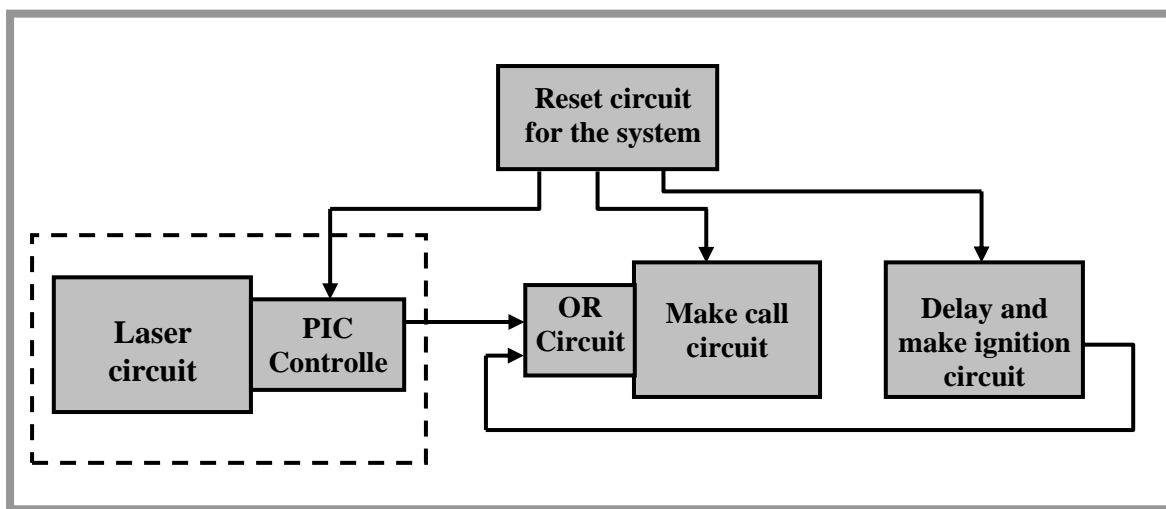

Fig. (1) General block diagram of wireless security system.

Fig. (2) illustrates the block diagram of the proposed security system which is consisting of the following parts:

1. Sensing System.
  - a. Laser circuit.
  - b. Control circuit.
2. Digital Video Recorder System.
3. Call circuit.
4. Delay and ignition circuit.
5. Reset circuit for the system.



*Fig. (2) Block diagram of the proposed security system.*

### 3.1 Sensing System

In this work, the function of the sensing system is to detect unauthorized access to a protected area. This system consists of two subsystems, laser intruder detecting system and controlling system. These two subsystems synchronized together to get the best detecting results. Where, four laser intruder systems synchronized with controlling system in a way making detecting process more effective as shown in Fig. (3).

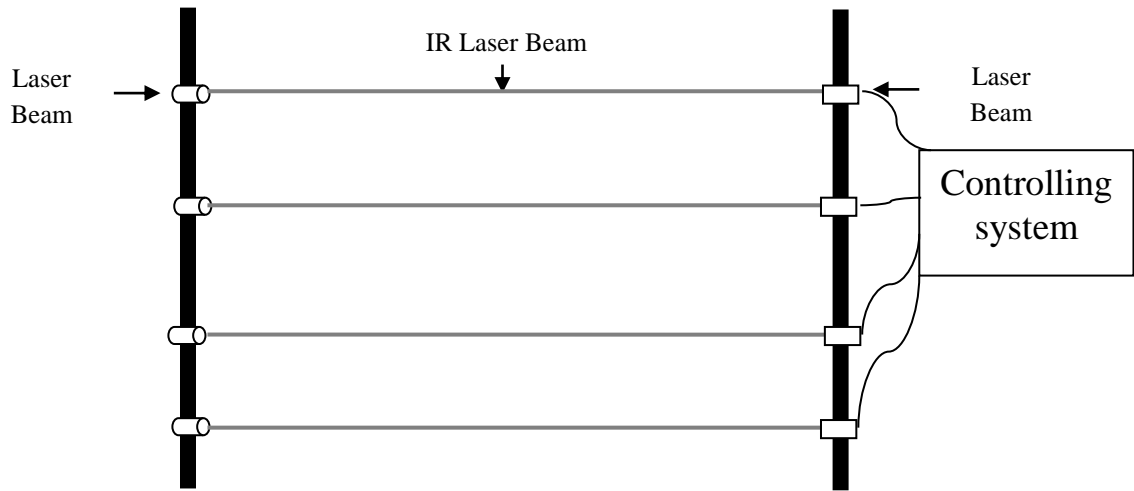

**Fig. (3) Sensing System.**

**3.1.1 Laser Intruder Detecting System**

Laser intruder detecting system consists of four groups of circuits, each one containing laser beam transmitter circuit and laser beam receiver circuit.

**a. Laser Beam Transmitter Circuit**

The major part in laser beam transmitter circuit is an IR semiconductor laser diode of power 20-30 mw as shown in Fig (4). In this circuit the IR laser beam transmitted through the access way of the protected area and detected by laser beam receiver circuit. Four laser transmitter and receiver circuits are used to make a grid of invisible laser beam in the way to the protected area. The path of the four laser beams are made to be in parallel. The distance between each laser beam is 0.5 m. When unauthorized person or object passes through this way, the grid will be broken where this action in receiver circuit gives an indication to the controlling system.

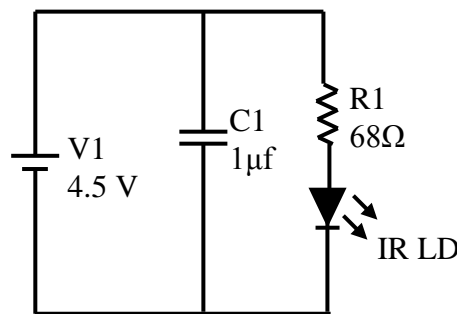

**Fig. (4) Laser beam transmitter circuit.**

**b. Laser Beam Receiver Circuit.**

The basic components in laser beam receiver circuit are:

1. The IR photo transistor (L14F1).
2. Op-amp (LF356N).
3. Monostable 555 timer.

These basic components are connected with other electronic components where they made together laser beam receiver circuit as shown in Fig (5). When the IR laser beam of the transmitter circuit falls on phototransistor of the receiver circuit the output of the op-amp remains high so the output of the monostable 555 remains low. This leads to deactivate the controlling system. When the laser beam is interrupted by the intruder, the output of op-amp becomes low and producing a pulse to trigger the monostable 555. The output of the 555 IC becomes high according to the trigger pulse which leads to activate the controlling circuit.

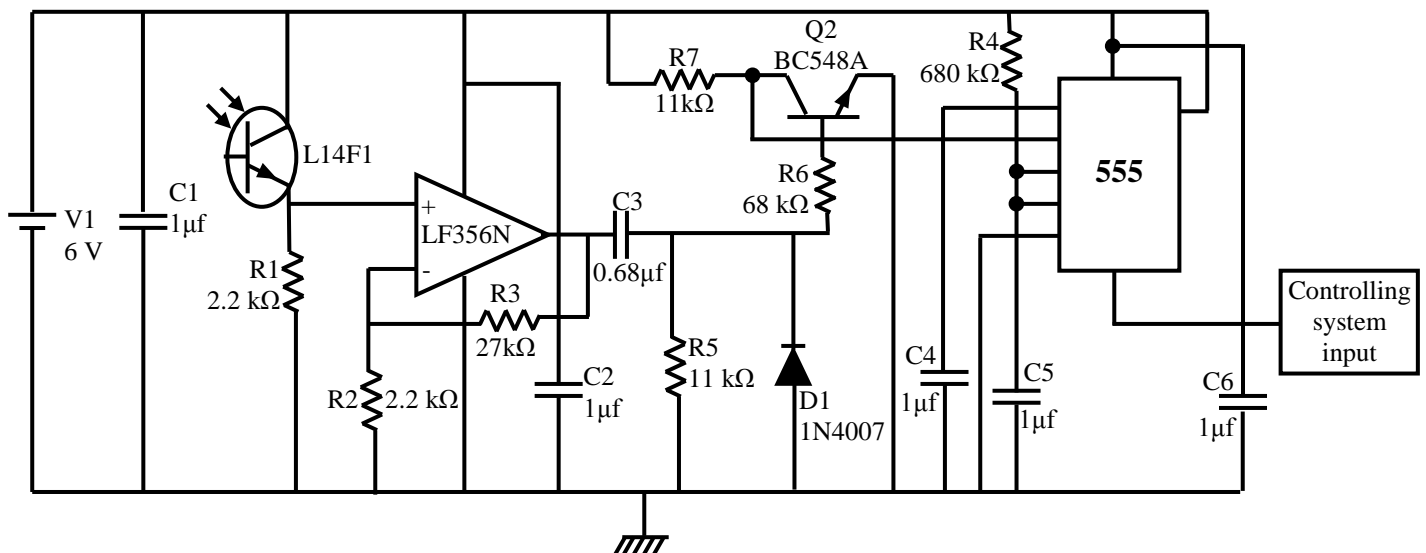

**Fig. (5) Laser Beam Receiver Circuit.**

**3.1.2 Controlling Circuit**

The microcontroller PIC18F452 shows in Fig. (6) is the main component in the controlling circuit. This microcontroller is considered as one of the best High Performance, Enhanced FLASH Microcontrollers with 10-Bit A/D. Where some of PIC18F452 features could be seen in Table (1) [11]. The main objective of controlling circuit is to give the sensing system and the calling system more accuracy and more stability. This objective is done by the way of programming the microcontroller PIC18F452 as shown in Fig (7).

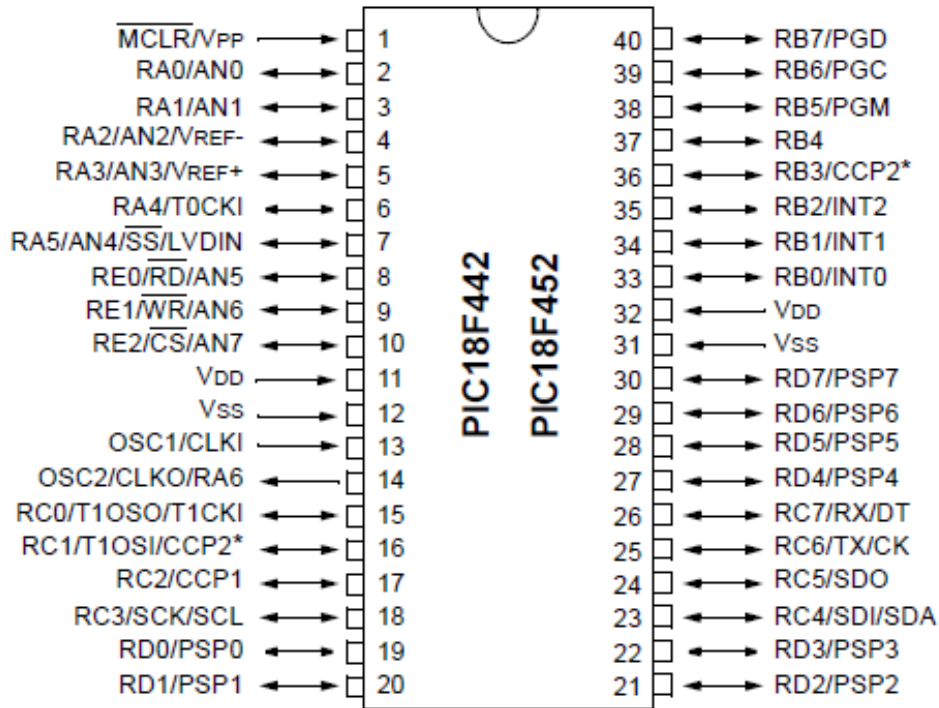

**Fig. (6) PIC18F452 pin configuration.**

The output signals from the four laser beam receiver circuits represent the input signal to the Microcontroller PIC18F452 as shown in Fig. (8). When more than one laser beam is interrupted, the Microcontroller PIC18F452 take an action and outputs an ignition pulse to the DVR system and the calling circuit to indicate that there is an unauthorized access to a protected area. If a single laser beam is interrupted the signal ignored and the microcontroller will not take any action.

**Table (1) PIC18F452 features.**

Features	18F452
Operating Frequency	DC- 40 MHz
Program memory (Bytes)	32K
Program memory (Instructions)	16384
Data Memory (Bytes)	1536
Data EEPROM Memory (Bytes)	256
I/O ports	Port A, B, C, D, E
Programmable Low voltage Detect	Yes
Reset and Delay	Yes
Parallel and serial communication	Yes

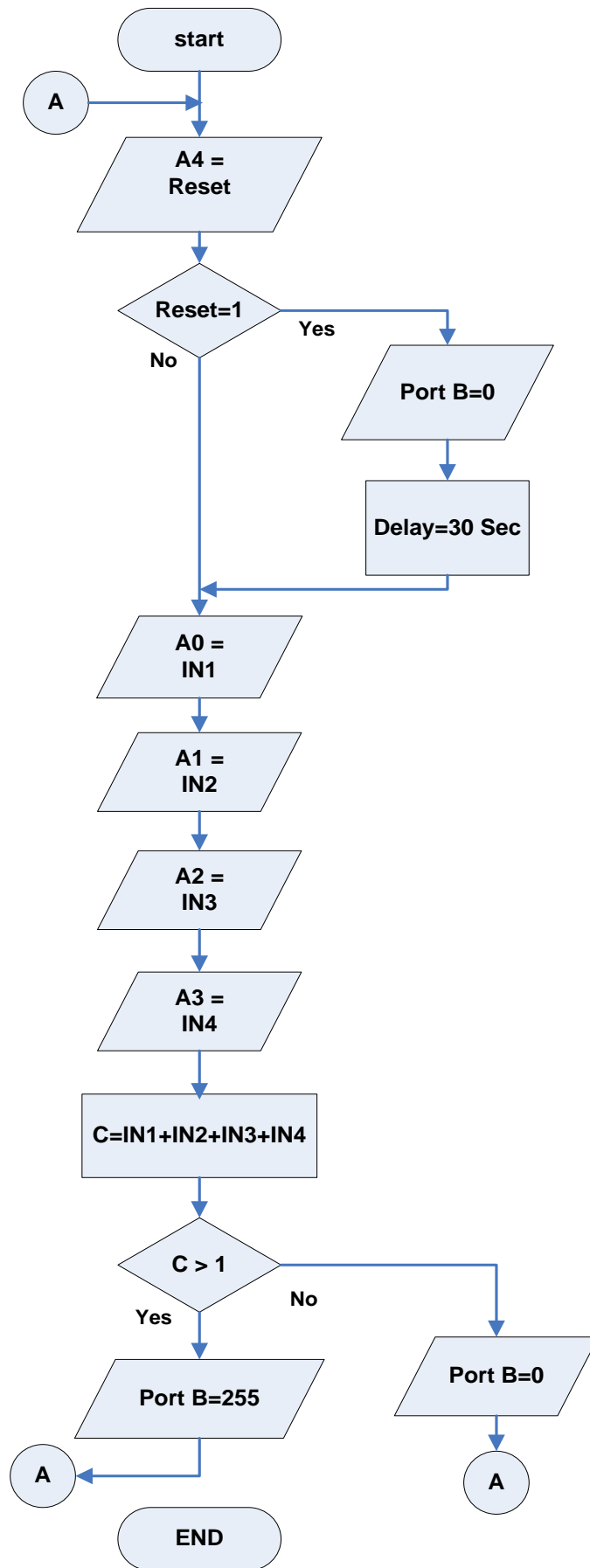

Fig. (7) PIC18F452 program flow chart.



The Microcontroller is programmed in a way in which it gives more accurate result to the system. The purpose of using a grid of four laser beams is to neglect the interrupting done by birds or animals which give a fake alarm when using this system in open places. The Microcontroller is programmed to reset with a delay of 30 sec when it is triggered by an input signal from the reset circuit.

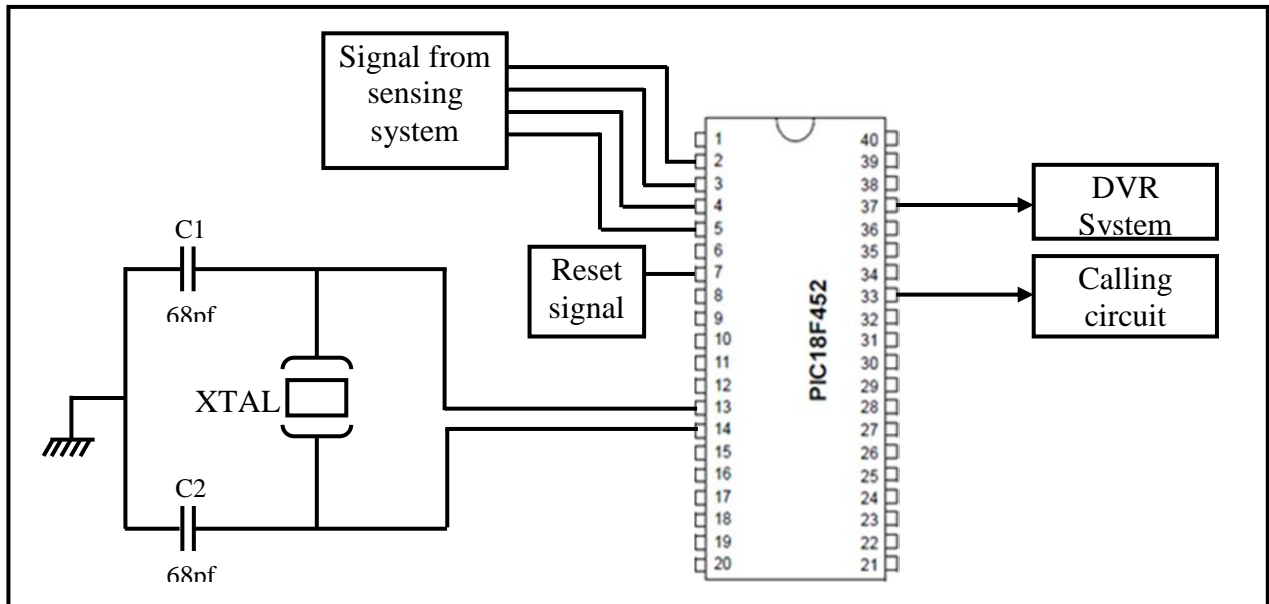

Fig. (8) Overall system design.

### 3.2 Digital Video Recorder (DVR) System

A Digital Video Recorder is a security system device that records video from surveillance cameras on a hard disk. In this work DVR system operates and starts recording from a connected camera when it receives a signal from the controlling system. Surveillance camera is set to monitoring and covering an important zone for the owner. DVR system can records video from 8 surveillance cameras on a hard disk capacity of 500GB. DVR and cameras operate at 220V AC, while the operating signal voltage from controlling system is about 5V DC so it needs to use a driver circuit to operate DVR and camera system as shown in Fig. (9).

### 3.3 Calling Circuit

One of the control circuit's output signals is used to activate the calling circuit. This circuit is responsible for making the calling process by activate speed dial function in mobile phone. The activation of speed dials function done by triggering key no. 2 for (3sec) as shown in Fig (10).

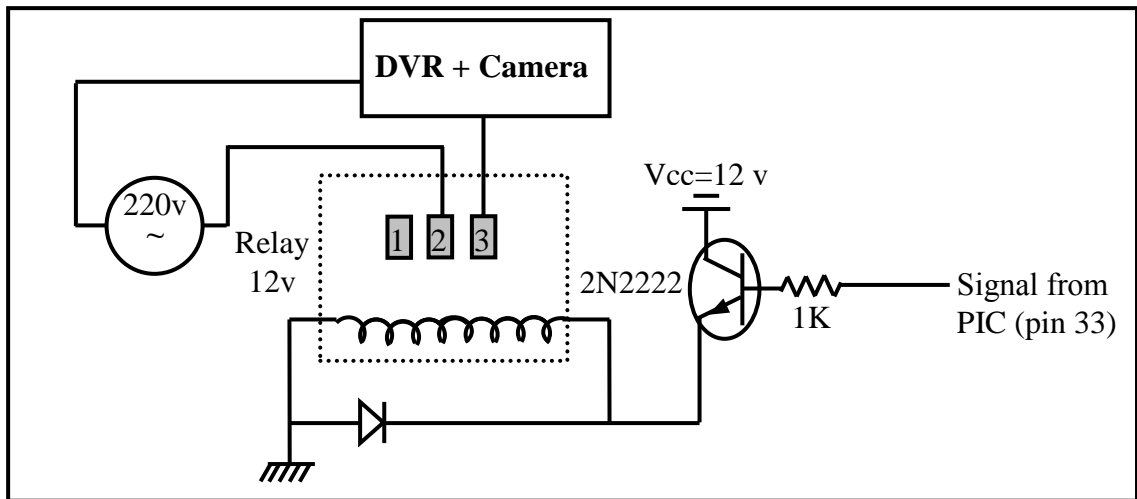

Fig. (9) Driver circuit of DVR & camera.

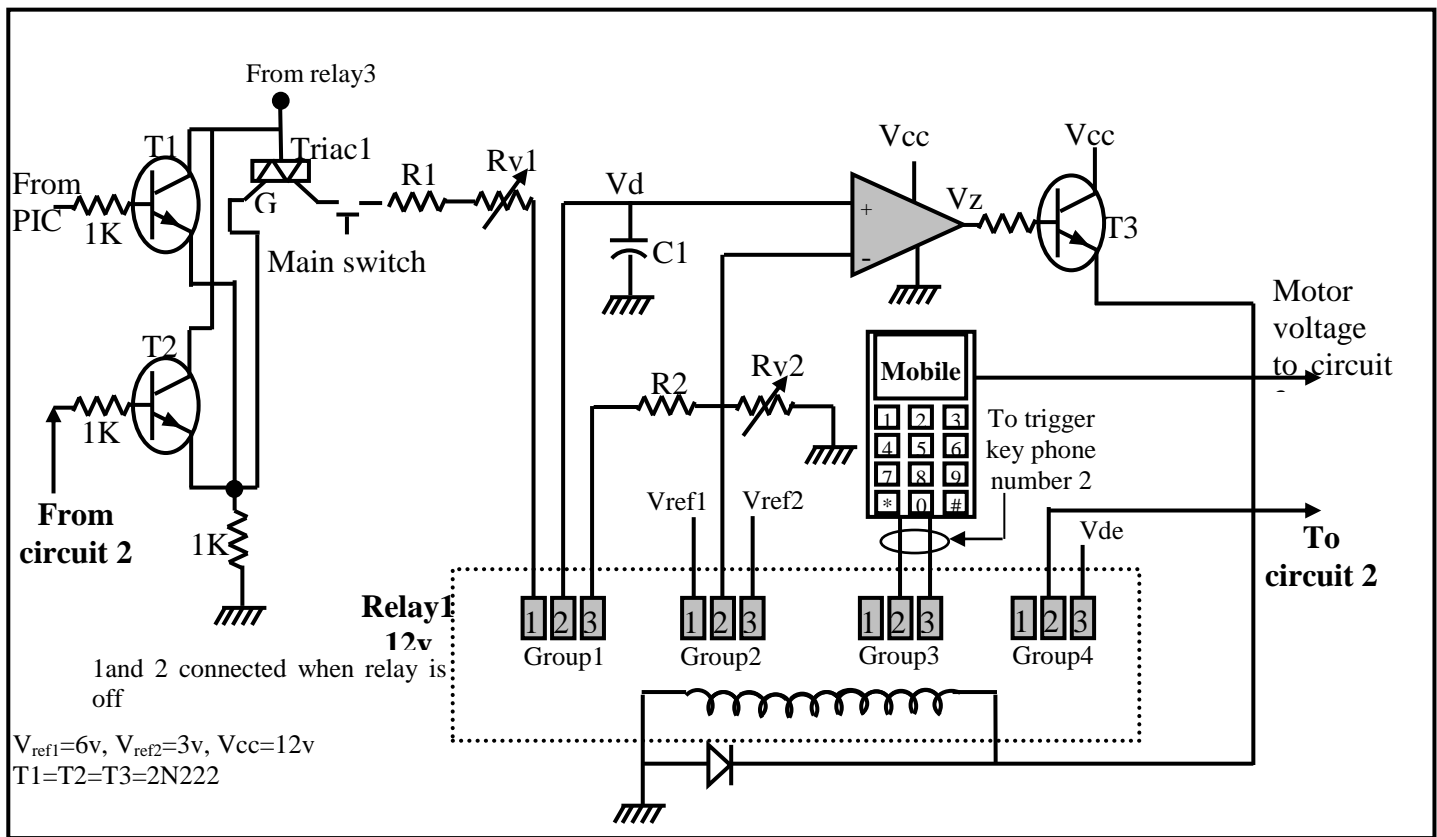

Fig (10) Circuit 1 (call circuit).

The operations of Relay1 are:

Group1: Connection 1 and 2 are used to make the charging time of (1sec.), which is the required time to establish the call with the remote mobile. While connections 2 and 3 are used for the discharging time (3sec.), which is the required time to press on key phone no. 2.

Charging and discharging times can be determined as follows:

$$T_1 = (R_1 + R_{v1}) * C_1 \dots\dots\dots (1)$$

Where  $T_1$  is the charging ( $T_1=5t$ ). This leads to ( $t$  must be 1 second).

Assume that  $C_1=47 \mu\text{f}$ , therefore  $(R_1+R_{v1}) =300\text{k}\Omega$ .

We used  $R_1=100\text{k}\Omega$  &  $R_{v2}=200\text{k}\Omega$  to make facility to change in the charging time ( $T_1$ ).

$$T_2 = (R_2+R_{v2}) * C_1 \dots\dots\dots (2)$$

Where  $T_2$  is the discharging ( $T_2=5t$ ). This leads to ( $t$  must be 3 second).

$C_1=47 \mu\text{f}$ , therefore  $(R_2+R_{v2}) =100\text{k}\Omega$ .

We used  $R_1=50\text{k}\Omega$  &  $R_{v2}=50\text{k}\Omega$  to make facility to change in the discharging time ( $T_2$ ).

Group2: 1 and 2 connecting  $V_{ref1}$  to the OP. Amp. at the charging period.

2 and 3 connecting  $V_{ref2}$  to the OP. Amp. at the discharging period.

Group3: connection 2 and 3 are used to press on key phone no. 2 in the mobile to make fast call to the remote mobile.

Group4: connection 2 and 3 are used to enable timer which is used to delay the calling with remote mobile again after (120 sec.).

**3.4 Delay and Make Ignition Circuit**

The delay and ignition circuit is designed to make delay time about (120 second) to complete the tons of calling in remote (mobile owner). After that, the output signal from the ignition circuit is used to make ignition repeatedly to the calling circuit through motivating the Triac1 of its circuit as shown in Fig. (11).

The operations of Relay2 are:

Group1: Connection 1 and 2 are used to make charging time (120sec.) which is the required time to delay another calling with the remote mobile.

Connection 2 and 3 are used to make discharging time (1sec.) which is the required time to make ignition to the first Triac.

Group2: 1 and 2 connecting  $V_{ref1}$  to the OP. Amp. at the charging period.

2 and 3 connecting  $V_{ref2}$  to the OP. Amp. at the discharging period.

Where:  $T_1=5t$ .  $t$  must be 120 second.

Assume that  $C_1=470 \mu\text{f}$ , therefore  $(R_{d1}+R_{dv1}) =545\text{k}\Omega$ .

We used  $R_{d1}=400\text{k}\Omega$  &  $R_{dv2}=150\text{k}\Omega$  to make facility to change in the charging time ( $T_1$ ).

Where:  $T_2=5t$ .  $t$  must be 2 second.

$C_1=470 \mu\text{f}$ , therefore  $(R_{d2}+R_{dv2}) =25\text{k}\Omega$ .

We used  $R_1=5\text{k}\Omega$  &  $R_{v2}=20\text{k}\Omega$  to make facility to change in the discharging time ( $T_2$ ).

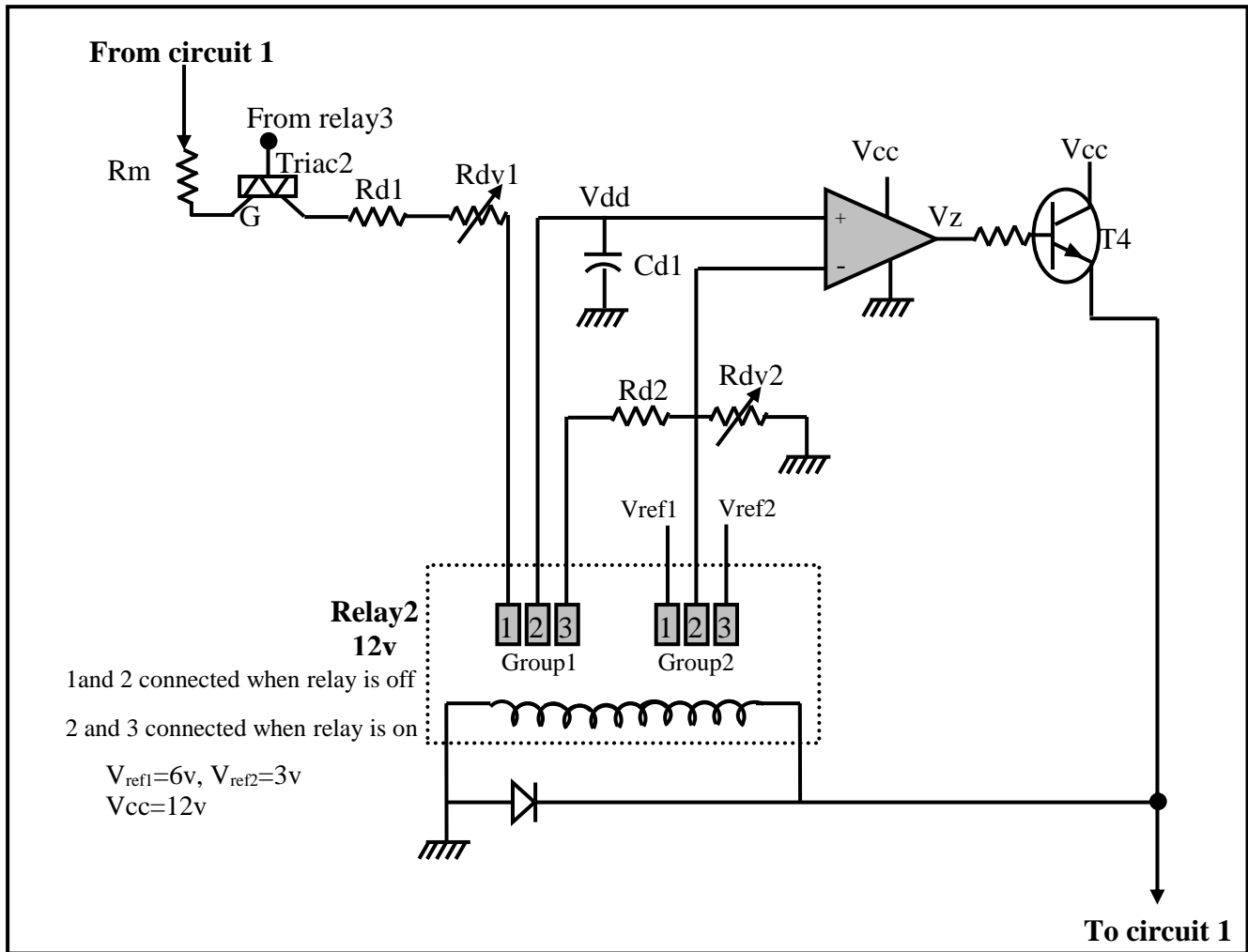

Fig (11) Circuit 2 (delay and make ignition circuit).

### 3.5 Reset Circuit for The System

The reset circuit is used to avoid the continuous repeatedly calling for the remote mobile. This mechanism is achieving by calling the fixed mobile from remote mobile to makes cut off the voltage in call circuit. Fig. (12) shows the reset circuit.

The operations of Relay 3:

In this circuit:

Group1: Connection 1 and 2 are used to make the Triac 1 (circuit 1) and Triac 2 (circuit 2) with voltage (12 volt).

Connection 2 and 3 are used to cut off the voltage for Triac 1 and Triac 2.

Group2: Connection 1 and 2 are used to activate the op-amp at the charging period.

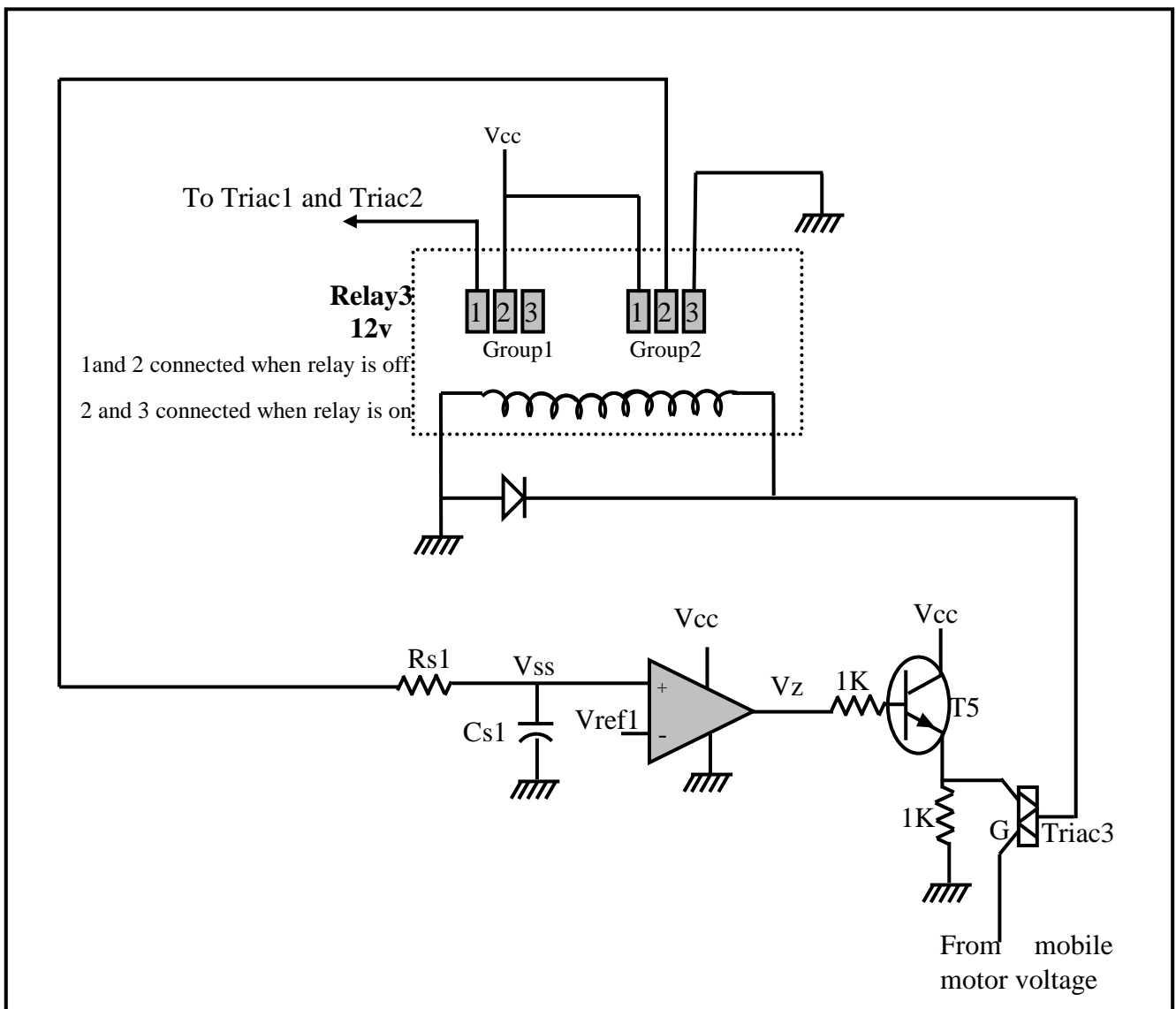

**Fig. (12) Circuit 3 (Reset circuit for the system).**

Connection 2 and 3 are used to activate the relay and cut off the voltage for Triac 1 and Triac 2. at the discharging period.

#### 4. Implementation of The Security System

System's hardware is built according to the designed circuits in which all of these circuits are connected together in addition to the mobile phone and the DC power supplies to complete the desired system.

The integral system is tested in different situations depending on the mechanism of laser grids in sensing system. Therefore, there was no dialing between the fixed and remote mobile phone and (DVR - camera) switches off when no event occur in sensing system as shown in Fig. (13).

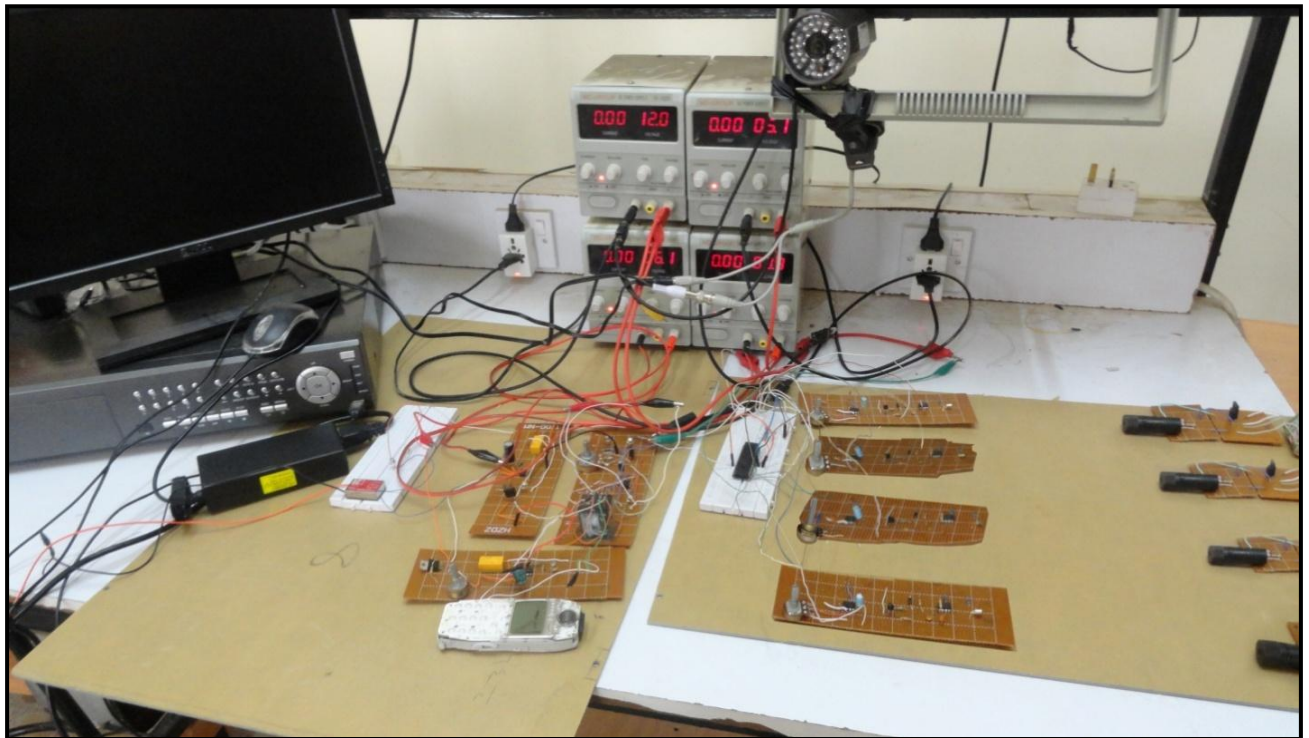

**Fig. (13) Overall system at secure state without interrupted.**

Fig. (14), illustrates the dialing between the fixed mobile and the remote mobile phone after the barrier cut off the laser beams grid in sensing system and the DVR began to records the events with through the digital camera and display it on monitor.

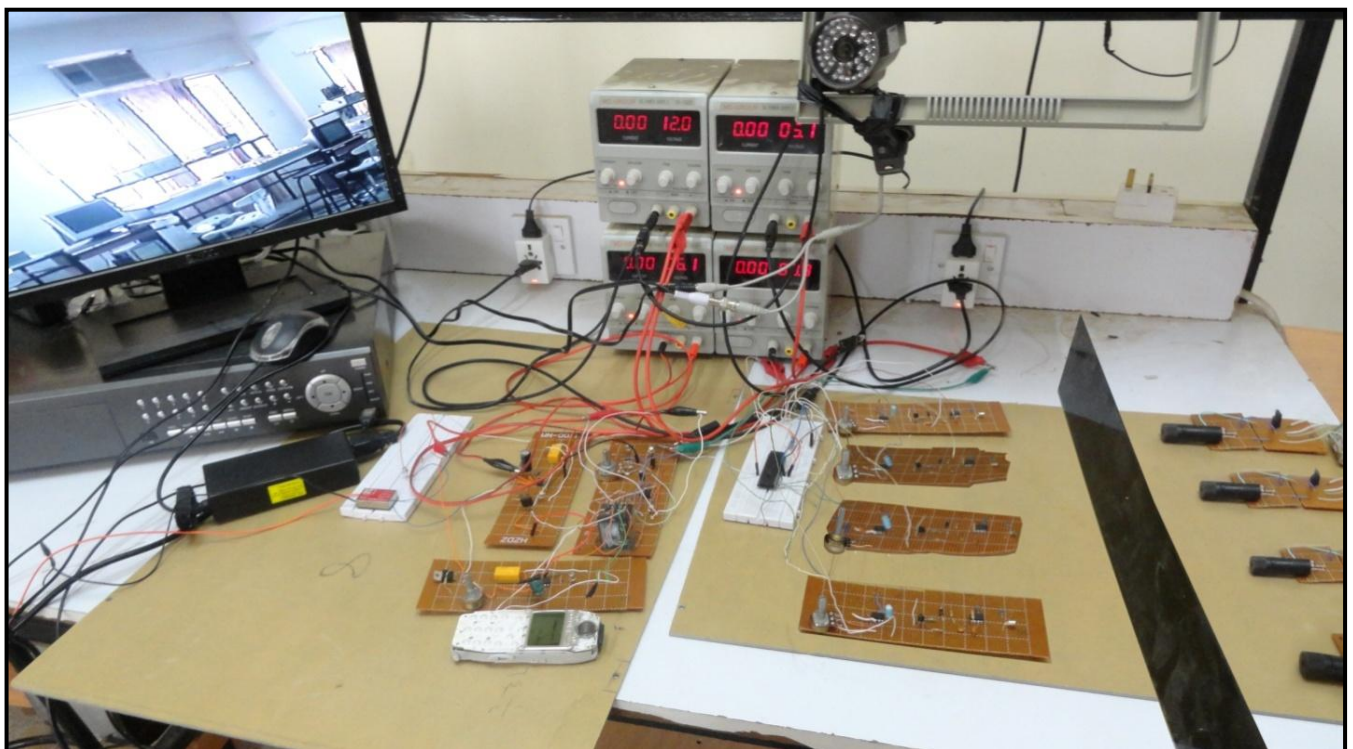

**Fig. (14) Overall system at unsecure state with intruder interrupted.**



## 5. Conclusions

1. The system is reliable in detecting an authorized access according to IR laser grid of sensing system which can be used at any place that need to be protected in addition to that, this system work according to the silent alarm principle where, it doesn't use alarm in system architecture.
2. The security system was built using two mobile phones. The first is a remote mobile and the second is a fixed mobile phone connected with many circuits to establish dialing between these two phones and executes the operations.
3. The values of  $V_{ref1}$  and  $V_{ref2}$  in relays 1&2 in calling circuit depended on the time of charging and discharging for press key no. 2 in mobile phone.
4. The delay time can be changed according to the period of calling tone in mobile phone.
5. The using of microcontroller (PIC18F452) in this work is related to its own features such as containing A/D converter, possibility for detecting low voltage and operates in high frequency.
6. The reset signal is employed to stop repeating call with the remote mobile and reset the control circuit which returns to sensing process.

## 6. References

- [1] K. Salram, N. Gunasekaran, and S. Rama Reddy, "**Bluetooth in Wireless Communication**", IEEE Communications Magazine, pp. 90-96, June 2002.
- [2]F. Rashidi, M. Ariff and M. Ibrahim, "**Car Monitoring using Bluetooth Security System**", International Conference on Electrical, Control and Computer Engineering Pahang, Malaysia, June 21-22, 2011.
- [3]R. sser and R. Pelz, "**Bluetooth-based wireless connectivity in an automotive environment**", Proc. IEEE Vehicular Technology Conf. — fall, vol. 4, pp. 1935 - 1942, 2000.
- [4] L. Nehmadi and J. Meyer, "**A System for Studying Usability of Mobile Security**", Third International Workshop on Security and Privacy in Spontaneous Interaction and Mobile Phone Use (IWSSI/SPMU), San Francisco, CA, USA, June 12, 2011.
- [5]K. Sohr, T. Mustafa and A. Nowak, "**Software Security Aspects of Java-Based Mobile Phones**", SAC'11, Taichung, Taiwan, March 21-25, 2011.
- [6]J. Abdullah, "**The Design of Mobile Control Car Security System**", IACSIT International Journal of Engineering and Technology, Vol.3, No.3, June 2011.

- [7]L. Yun and Y. YinGen, “**Design and Implementation of A Mobile Phone Integrated Alarming-System**”, International Conference on Multimedia Information Networking and Security, IEEE, 2009.
- [8]B. Wu, H. Peng and C. Chen, “**A Practical Home Security System via Mobile Phones**”, Proceedings of the 5th WSEAS International Conference on Telecommunications and Informatics, Istanbul, Turkey, pp. 299-304, May 27-29, 2006.
- [9]L. Yang, S. Yang, and F. Yao, “**Safety and Security of Remote Monitoring and Control of intelligent Home Environments**”, IEEE, International Conference on Systems, Man, and Cybernetics, Taipei, Taiwan, October 8-11, 2006.
- [10]I. Liao, “**Infrared Remote Control Based on LCD Displayer and Speech Synthesizer**”, M.S. Theses of Electronic Engineering Dept., National Taiwan Technology and Science University, 2007.
- [11]J. Peatman, “**Embedded Design with the PIC18F452 Microcontroller**”, Prentice Hall, 2003.